

---

# White Paper on Truck Parking

## CAR 2 CAR Communication Consortium



---

### About the C2C-CC

Enhancing road safety and traffic efficiency by means of Cooperative Intelligent Transport Systems and Services (C-ITS) is the dedicated goal of the CAR 2 CAR Communication Consortium. The industrial driven, non-commercial association was founded in 2002 by vehicle manufacturers affiliated with the idea of cooperative road traffic based on Vehicle-to-Vehicle Communications (V2V) and supported by Vehicle-to-Infrastructure Communications (V2I). The Consortium members represent worldwide major vehicle manufactures, equipment suppliers and research organisations.

Over the years, the CAR 2 CAR Communication Consortium has evolved to be one of the key players in preparing the initial deployment of C-ITS in Europe and the subsequent innovation phases. CAR 2 CAR members focus on wireless V2V communication applications based on ITS-G5 and concentrate all efforts on creating standards to ensure the interoperability of cooperative systems, spanning all vehicle classes across borders and brands. As a key contributor, the CAR 2 CAR Communication Consortium and its members work in close cooperation with the European and international standardisation organisations.

---

### Disclaimer

The present document has been developed within the CAR 2 CAR Communication Consortium and might be further elaborated within the CAR 2 CAR Communication Consortium. The CAR 2 CAR Communication Consortium and its members accept no liability for any use of this document and other documents from the CAR 2 CAR Communication Consortium for implementation. CAR 2 CAR Communication Consortium documents should be obtained directly from the CAR 2 CAR Communication Consortium.

Copyright Notification: No part may be reproduced except as authorized by written permission. The copyright and the foregoing restriction extend to reproduction in all media. © 2024, CAR 2 CAR Communication Consortium.

---

## Document information

---

<b>Number:</b>	2312	<b>Version:</b>	1.0	<b>Date:</b>	2024-11-04
<b>Title:</b>	White Paper on Truck Parking			<b>Document Type:</b>	WP
<b>Release</b>	N.a.				
<b>Release Status:</b>	Public				
<b>Status:</b>	Final				

**Table 1: Document information**

---

### Changes since last release

---

Release	Date	Changes	Edited by	Approved
1.0	2024-11-04	initial release	Release Management	Steering Committee

**Table 2: Changes since last release**

## Table of contents

About the C2C-CC .....	1
Disclaimer .....	1
Document information .....	2
Changes since last release.....	3
Table of contents.....	4
List of tables .....	5
List of Figures .....	6
1 Introduction.....	8
2 Description of Work Item and Objectives .....	11
3 Acronyms, Abbreviations and Definitions.....	13
4 Truck parking in Europe .....	15
4.1 Austria.....	15
4.2.2 General Information.....	15
4.2.2 Parking Information .....	16
4.2.2 Queue Parking .....	17
4.2 Belgium .....	18
1.1.1 General Information.....	18
1.1.2 Parking Information .....	19
4.3 Czech Republic.....	19
1.1.3 Types of Parking Facilities .....	20
1.1.4 Parking Information .....	22
4.4 Denmark .....	22
1.1.5 Types of Parking Facilities .....	22
1.1.6 Parking Information .....	23
4.5 France .....	24
1.1.7 General Information.....	24
1.1.8 Parking Information .....	24
4.6 Germany .....	24
1.1.9 General Information.....	24
1.1.10 Parking Information .....	29
4.7 Greece .....	32
1.1.11 General Information.....	32
1.1.12 Parking Information .....	34
4.8 The Netherlands.....	34
1.1.13 General Information.....	34
1.1.14 Parking Information .....	37
4.9 Sweden .....	37
1.1.15 General Information.....	37
1.1.16 Parking Information .....	39
4.10 Alternative Parking Solutions.....	39
1.1.17 KRAVAG Truck Parking.....	39
1.1.18 OTRA Truck Parking .....	39
4.11 Types of detection.....	39
1.1.19 Entrance and Exit Detection.....	40
1.1.20 Area detection .....	40
1.1.21 Single space detection.....	40

5	Standards and Regulations .....	41
5.1	C-Roads.....	41
5.2	ETSI.....	41
6	Use Cases.....	42
6.1	Use Case 1 ‘Free Capacity’ detected by infrastructure.....	44
6.2	Use Case 2 ‘Free Capacity’ detected by geofence.....	47
6.3	Use Case 3 ‘Dangerous Parking Position’ .....	49
6.4	Use Case 4 ‘Misuse of parking space (originated by truck)’ .....	52
6.5	Use Case 5 ‘Misuse of parking space (originated by infrastructure)’ .....	55
6.6	Use Case 6 ‘Dangerous parking’ (outside official parking infrastructure).....	57
6.7	Use Case 7 ‘Dangerous parking’ (outside official parking infrastructure).....	60
6.8	Use Case 8 ‘Departure Time’ (truck in right lane).....	62
6.9	Use Case 9 ‘Departure Time’ (truck in wrong lane)).....	65
6.10	Use Case 10 ‘Guidance to free parking place’ (list+map).....	67
6.11	Use Case 11 ‘Guidance to free parking place’ (list).....	70
6.12	Use case 12 ‘Warn approaching vehicles’ .....	73
2	Message Types, Triggering Conditions and Message Content .....	75
3	Appendix.....	81
6.13	Related documents .....	81
6.14	Use Cases which did not fit to the initial criteria but might be interesting in the future	
	82	
3.1.1	Use Case 13 ‘Where is my trailer?’.....	82
3.1.2	Detection of free parking spaces by trucks.....	85

## List of tables

Table 1: Document information.....	2
Table 2: Changes since last release .....	3
Table 3: Definitions .....	14
Table 4: Template for the description of a use case.....	43
Table 5: Description of use case 1 .....	47
Table 6: Description of use case 2 .....	49
Table 7: Description of use case 3 .....	52
Table 8: Description of use case 4 .....	55
Table 9: Description of use case 5 .....	57
Table 10: Description of use case 6 .....	60
Table 11: Description of use case 7 .....	62
Table 12: Description of use case 8.....	65
Table 13: Description of use case 9.....	67

Table 14: Description of use case 10..... 70

Table 15: Description of use case 11..... 72

Table 16: Description of use case 12..... 74

Table 17: List of defined use cases and the required C-ITS messages per use case..... 80

## List of Figures

Figure 1: Example for a parking truck in an emergency lay-by..... 9

Figure 2: Example for truck blockings and limited paths at a truck parking site in Germany (Autohof Dasing A8)..... 10

Figure 3: Example for a medium parking site with sanitary infrastructure..... 15

Figure 4: Example for a big parking site with infrastructure..... 16

Figure 5: Example for truck parking information in Austria (picture: Asfinag)..... 17

Figure 4-6 Queue Parking ASFIANG (@ASFIANG, <https://www.asfinag.at/parken-rasten/lkw-stellplatze/truck-stop-hausruck/>) ..... 17

Figure 7: Example for a small parking site without infrastructure. .... 18

Figure 8: Example for a big parking site with infrastructure. .... 19

Figure 9: Example for a big parking site at the border to Germany with single access to the parking places which can easily be converted into a queue parking site..... 20

Figure 10: Example for a small parking site on the D5. .... 21

Figure 11: Example for a big parking site at the D5 with a classical arrangement of parking places in three rows..... 21

Figure 12: Example for parking site at the E45 with a classical arrangement of parking places in one row. .... 22

Figure 13: Example for parking site at the E45 with truck parking spaces which are occupied by passenger cars..... 23

Figure 14: Example for parking site at the E45 with a classical arrangement of parking places in one row. .... 24

Figure 15: Example for a small parking area without infrastructure ..... 25

Figure 16: Example for a medium parking area with sanitary infrastructure..... 26

Figure 17: Example for a big parking site with extended infrastructure..... 26

Figure 18: Example for a private parking site located at a motorway interchange ..... 27

Figure 19: Detection and identification of truck at entry and exit..... 28

---

Figure 20: Detection of parking trucks by laser scanner .....	28
Figure 21: Queue parking at Jura West.....	29
Figure 22: BayernInfo information on truck parking capacity on the A9 motorway.....	30
Figure 23: Occupancy of the parking lanes of a queue parking site .....	30
Figure 24: Example for the roadside information of free parking spaces for trucks in Germany .....	31
Figure 25: Example for a system, warning drivers entering a rest area or parking site (Die Autobahn 2024) .....	32
Figure 26: Example for a secure parking site on the A1 in Greece.....	33
Figure 27: A5 Ionia Odos motorway safe and secure truck parking Episkopiko .....	34
Figure 28: A15 Parking site of smaller size.....	35
Figure 29: A1 Parking site of bigger size.....	36
Figure 30: A1 Parking site of bigger size with big green parts.....	37
Figure 31: A1 Plans showing commercial and federal parking sites (left) and sites with the need for further infrastructure (right) .....	38
Figure 32: UML-sequence of use case 1.....	44
Figure 33: UML-sequence of use case 2.....	47
Figure 34: UML-sequence of use case 3.....	50
Figure 35: Example of a truck occupying two parking spaces .....	52
Figure 36: UML-sequence of use case 4.....	53
Figure 37: UML-sequence of use case 5.....	55
Figure 38: UML-sequence of use case 6.....	58
Figure 39: UML-sequence of use case 7.....	60
Figure 40: UML-sequence of use case 8.....	63
Figure 41: UML-sequence of use case 9.....	65
Figure 42: UML-sequence of use case 10 .....	67
Figure 43: UML-sequence of use case 11 .....	70
Figure 44: UML-sequence of use case 12 .....	73
Figure 45: Trailer parked aside the road .....	84

## 1 Introduction

Truck parking and the problems with less capacity of the parking sites is an issue which is known in many of the European countries. The recent version of the European directive for the deployment of ITS is considering truck parking as a relevant topic for the next years. Besides the classical technical solutions as there are detection systems and parking information, there are several parking use cases where management and safety can be enhanced by cooperative ITS communication.

This includes

- city parking,
- private parking (open space, parking garage),
- semi-public parking (e.g. Park and Ride) or
- motorway parking, especially the parking of trucks.

This work item will focus on motorway truck parking, since this use case was identified to be a perfect starting point for a common parking message set, with extensions for IVI, POI, and DENM.

No common C-ITS parking service is specified up till now. Several existing partly contradicting proposals should be harmonized to avoid a multitude of not standardized communication interfaces.

Up to 2024 the implementations of cooperative systems cover mainly the day 1 use cases. All further use cases specified in [12] of day 2 or day 3+ are dealing with driving use cases which are related to driving processes and automated driving. As truck parking is not yet covered in the use case road map, we will state a use case level of day x.

Especially truck parking along motorways is a serious safety issue, as there is a too low capacity of parking spaces which leads to parking trucks in critical areas like along the motorway (see Figure 1) and in entrance and exit ramps.



**Figure 1: Example for a parking truck in an emergency lay-by**

Figure 2 gives a good example of the problems truck drivers encounter if they are looking for a parking space or trying to enter or exit a parking space

(<https://goo.gl/maps/eWXgayCJUwDQXm9T6>)

Critical situations in Figure 2 are marked by numbers.

1. Truck is not exactly parked, exceeds the parking space and is limiting the access lanes.
2. Truck prevents the forward exit of the second one in the row left. This one first must drive backwards before leaving.
3. This one is exceeding the parking space and limiting the access lanes.
4. This truck is blocking the exit of another truck.
5. Trucks are blocking the access lanes.



Figure 2: Example for truck blockings and limited paths at a truck parking site in Germany (Autohof Dasing A8)

---

## 2 Description of Work Item and Objectives

---

Other than the rest of the drivers, truck and bus drivers are obliged to have breaks and rests during their trip. These breaks and rests are defined by law and are enforced by the authorities. This fact is the main motivation for the driver behaviour and puts major pressure on the drivers to find an empty parking space in time, without:

- long search,
- cruising around,
- manoeuvring,
- interrupting the break,
- blocking entries and exits and
- parking in dangerous areas.

Additional requirements as charging or special needs for dangerous goods complicate the search for an appropriate parking space.

The work will first identify the truck parking situation and truck parking problems in different European countries. The document will describe which types of motorway parking sites exist in the different countries and which technical systems currently are installed to monitor the area and to organize parking.

Based on this situation the document describes use cases to solve the most urgent problems, to improve safety and to ease the search for free parking spaces. A template has been defined which helps to describe each use case in the same way. Furthermore, a UML-sequence is added to each use case to visualize the process of information exchange and to identify the involved parties.

The focus of the work is set on motorway parking facilities with sometimes limited digital infrastructure and no or only a few detection systems.

Synergies with cloud-based services are a prerequisite and are not in scope of this work item. The truck parking guidance system brings information about free parking spaces at rest areas and truck stops into the driver's cab. The system records the occupancy of the individual parking facilities very precisely and automatically feeds the occupancy data into the central system via the route stations. From there, it can be made available to a wide variety of information platforms. In addition, operators in the central system can intervene at any time and trigger targeted measures to avoid dangerous situations. This is also economically feasible for large parking facilities - thanks to indirect or direct occupancy measurement, vehicles are counted and classified. The current parking space occupancy can be accessed by truck drivers via the TMC service of the radio stations, apps, Onboard Units of the truck fleets and the traffic information portals.

Use cases of trucks, parking their trailers somewhere in the road network and leaving the site, are not considered here, as they are not related to official parking places and would require some infrastructure on the trailer or a roadside station in the vicinity to continuously resend messages.

A possible further component of a parking guidance system can be the management of truck parking space through intelligent use of existing traffic areas. The aim is to achieve optimum utilization of space by concentrating supply on the departure times with the highest demand when the parking site is full. The information required for this is generated by intelligently

linking the data collected in the parking system. Arriving drivers decide for themselves where to park based on their planned departure time and vehicle dimensions.

But the current occupancy level is not the only challenge. The forecast for free parking spaces, which are adapted to the respective driving behaviour, should be as accurate as possible.

Using ITS-G5 as low latency communication medium offers beside the short-term parking space reservation the possibility of real-time local services within radio range, like vehicle tracking, actual parking lot occupancy information, way guidance, and with additional sensors other safety relevant services on parking lots not in scope of this work like blind spot and collision warnings.

- Cooperation with ETSI / Input from ETSI from the beginning is essential
- Cooperation with C-Roads

The new document will specify a basic set of C-ITS extensions for I2V messages like IVI, POI, and DENM to support motorway truck parking use cases. Including the description of their use for safety applications. Synergies with cloud-based parking management services will be outlined as basis for some use cases, but not specified in the new document.

### 3 Acronyms, Abbreviations and Definitions

The basic definitions for the understanding of the document can be found in Table 3. For further definitions please refer to the CEN/ISO role model ISO/TS 5206-1 Intelligent transport systems – Parking.

CAM	Cooperative Awareness Message
central ITS sub-system	Backbone, receives and generates messages, part of an ITS central system
DENM	Decentralized Environmental Notification Message (réf. ETSI standard for C-ITS messages)
ITS station (ITS-S)	global name for any of the ITS sub-systems
ITS-S application	App running on any ITS-station (roadside, personal, vehicle) using ITS-S service
ITS-S service	Provision of data and information using ITS-S stations
IVIM	Infrastructure to Vehicle Information Message (réf. ETSI standard for C-ITS messages)
Parking site (place)	premises for parking contains many parking spaces  there exist parking sites with and without reservation
parking area	group of parking spaces for defined types of vehicles sharing the same rules, there can be areas for e.g. passenger cars, trucks, busses, dangerous goods vehicles, refrigerator trucks
parking space	place to park one truck (= parking lot)
personal ITS sub-system	In-hand-held device
queue parking	sometimes named convoy parking, queue parking describes a special parking principle of arranging the parking trucks in rows, where all vehicles of a row have the same departure time range
roadside ITS sub-system	ITS station on gantries, poles, etc.,
tachograph	The tachograph is the device that records driving time, breaks and rest periods as well as periods of other work and availability of

---

	drivers engaged in the carriage of goods or passengers by road.
truck rest area	A truck rest area can include a parking site, restaurants, gas station, washrooms, vehicle services, etc.
vehicle ITS sub-system	In-vehicle device for ITS services

**Table 3: Definitions**

## 4 Truck parking in Europe

This chapter discusses the situation of truck parking in different European countries related to:

- parking sites
- the size and the organization of parking sites
- problems of truck parking processes
- implemented technical solutions (detection, signage)

There was an attempt to cover as many European countries as possible, but there was no or few input from some countries. One cannot conclude from a country which is not listed here, that there are no truck parking problems or that there is no truck parking at all.

### 4.1 Austria

#### 4.2.2 General Information

This chapter deals with parking sites on the motorways in Austria. ASFINAG, the road operator for the express and motorway network in Austria, offers 59 resting sites, 87 service stations and additional 108 parking lots along the road. The parking sites differ in size, layout and available facilities. Based on the infrastructure, the access can vary. Figure 3 shows a small/medium sized parking lot, Figure 4 shows a bigger resting site with a petrol station and hotel.



**Figure 3: Example for a medium parking site with sanitary infrastructure**



Figure 4: Example for a big parking site with infrastructure

#### 4.2.2 Parking Information

On-trip parking information is available along the motorway via dynamic, full graphic VMSs. These VMSs contain information about the closest parking sites for trucks, the distance and at which road they are located. An indicator for the remaining capacity is included. The capacity is detected by the local traffic management. Further, ASFINAG provides the information on their website and offers webcams to the sites so drivers can look by themselves as well.



Figure 5: Example for truck parking information in Austria (picture: Asfinag)

#### 4.2.2 Queue Parking

In 2024, ASFINAG opened the state-of-the-art “Truck Stop Hausruck” – introducing queue parking. Queue parking allows trucks to parking in a row, which maximizes the utilization of the existing space. The driver selects a departure time and gets a space assigned. An automatic detection system monitors the site and provides real-time information of the available space. Additionally, high power and overnight e-charging systems, showers, energy supply for refrigerated trucks, fitness devices and more facilities are provided.



Figure 4-6 Queue Parking ASFIANG (@ASFIANG, <https://www.asfinag.at/parken-rasten/lkw-stellplatze/truck-stop-hausruck/>)

## 4.2 Belgium

### 1.1.1 General Information

In Flanders a study has been issued (<https://www.tmlouven.be/nl/project/visie-vrachtwagenparkeren>) analyzing the situation of truck parking and looking for solutions which are evaluated on feasibility.

It is likely that the situation in Wallonia tends to be similar. An area which is most problematic is the area in the triangle Gent-Brussels-Antwerp. It extends along the A17 to the French boarder. As a matter of the missing truck parking capacity on motorway, parking in the secondary network is a problem in some areas.

A total of over 5,300 long-term parking events per day are measured in Flanders. Parking on the secondary road network is often linked to the function of the location.

Areas attracting freight traffic (industrial zones, airports, ports) have more trucks parked along the road. Of the total number of trucks parked, about one-fifth are parked in unofficial parking lots.



Figure 7: Example for a small parking site without infrastructure.



**Figure 8: Example for a big parking site with infrastructure.**

Besides the regular open parking sites there are secure parking sites like the one on motorway A40 near Wetteren.

### 1.1.2 Parking Information

There is no information available.

## 4.3 Czech Republic

Truck parking on motorways is an issue in the Czech Republic. The situation can be compared with the situation in other European countries like Austria or Germany. In the

Czech Republic parking sites can be found along the motorways and aside the motorways. Parking sites with direct access from and to the motorway are free of charge.

In recent years different European and national research projects like Ursa Major and Ursa Czech Republic have been initiated which deal with the topic of truck parking and parking information. In the Czech Republic different parking sites (approx. 6) along motorways have been equipped with detection equipment and a central system. The Czech Road and Highway Authority is currently equipping new and newly renovated Parking sites with detection.

A guideline is defining the type of detection system. The preferred system are in ground sensors for single space detection. <https://www.rsd.cz/technicke-dokumenty/ppk-a-dopravni-znaceni>

### 1.1.3 Types of Parking Facilities

In the Czech Republic different type of parking sites exist.

Figure 9 shows a big parking site on the D5 at the border with Germany. It shows an untypical organization of parking places. There are rows of 5 trucks parking in parallel. If additional capacity is required, they can easily be rearranged to rows for consecutive parked trucks (queue parking).



**Figure 9: Example for a big parking site at the border to Germany with single access to the parking places which can easily be converted into a queue parking site.**

Many parking sites are rather small and just offer fueling capacity and some parking places.



Figure 10: Example for a small parking site on the D5.



Figure 11: Example for a big parking site at the D5 with a classical arrangement of parking places in three rows.

### 1.1.4 Parking Information

The central system is responsible for the collection of the data and the dissemination of information via API and website and in the future also via VMS along the motorway. Each VMS shall indicate the capacity of the next and second next parking site.

Besides the current process of detecting occupancy, a forecast is done using standard time series.

## 4.4 Denmark

### 1.1.5 Types of Parking Facilities

There was no detailed information available about the Danish situation related to truck parking on motorways. The screenshots from Google show that there are parking sites along Danish motorways which are of smaller to medium size. It is not known whether there are private parking sites.

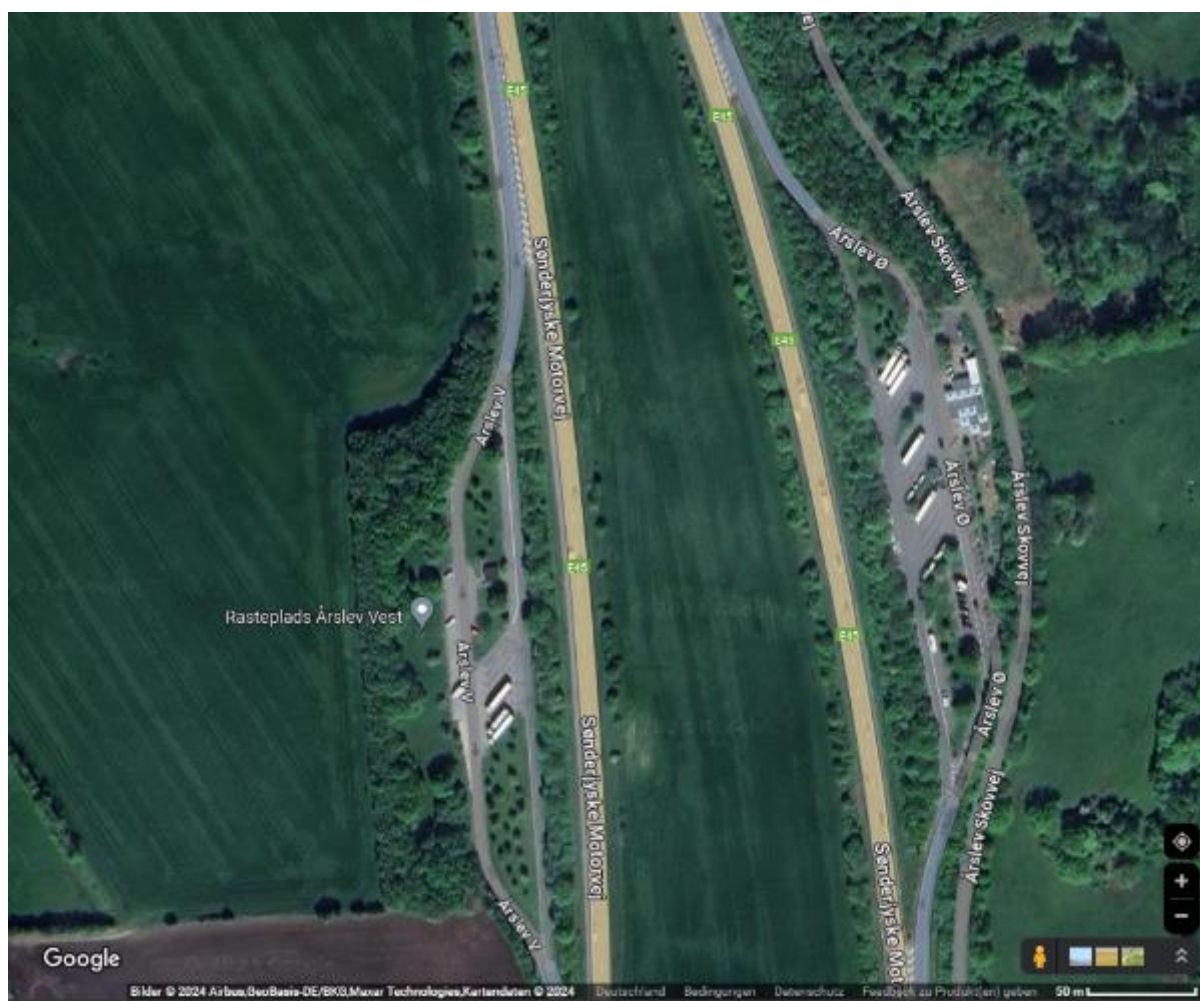

Figure 12: Example for parking site at the E45 with a classical arrangement of parking places in one row.

Figure 13 shows a parking site on the E45 with truck parking places which partially are occupied by passenger cars. This is not an issue during daytime but should not happen during night-time when parking spaces for truck are limited due to the legal rest period.



**Figure 13: Example for parking site at the E45 with truck parking spaces which are occupied by passenger cars.**

The parking site Ustrup Ost on the E45 uses queue parking for trucks

### 1.1.6 Parking Information

There are signs installed on the motorway E45 as shown in Figure 14 indicating the next parking sites. Each sign can indicate the number of free parking spaces. This indication seems to be currently inactive.



Figure 14: Example for parking site at the E45 with a classical arrangement of parking places in one row.

## 4.5 France

### 1.1.7 General Information

There is no information available.

### 1.1.8 Parking Information

There is no information available.

## 4.6 Germany

### 1.1.9 General Information

This chapter deals with parking sites in Germany.

A report of the German government on the prevention of accidents in road traffic [Deutscher Bundestag Drucksache 20/4580 --- Unfallverhütungsbericht 2020/2021 der Bundesregierung](#)

is stating, that the BMDV is continuously increasing the number of parking spaces. There are 1.900 rest areas (2022) with 54.400 parking spaces. Additional 19.000 parking spaces are available at private parking sites (Autohöfe). Despite that the demand is far above the number of available parking spaces.

The activities to improve the truck parking situation at rest areas and near the BAB were therefore bundled in a 5-point plan in 2020:

- Projects for the extension of existing parking sites and the building of new ones are planned and realized by the Autobahn GmbH.
- Extended use of telematics for parking processes including e.g. queue parking to increase the capacity.
- Reduction of truck parking search traffic by using detection infrastructure.
- Achieving an optimum use of the parking sites e.g. by allowing the parking in restricted areas during night-time or backwards parking for trucks.
- Check of new parking models near motorways especially in industrial areas.

There are two major types of parking areas considered in this document. The first ones are parking sites accessible from motorway by ramps to and from the parking site. Those types are operated by the Autobahn GmbH des Bundes. There are various sub-types which can be distinguished by the size and the available infrastructure. The smaller ones have no infrastructure.



**Figure 15: Example for a small parking area without infrastructure**



**Figure 16: Example for a medium parking area with sanitary infrastructure**

There are others with sanitary infrastructure and the biggest ones have tank stops and restaurants.



**Figure 17: Example for a big parking site with extended infrastructure**



**Figure 18: Example for a private parking site located at a motorway interchange**

Some of the bigger parking sites are equipped with infrastructure to detect the capacity. Those are either equipped with detectors for counting vehicles at the entrance and exit lanes or they are equipped with laser scanners.

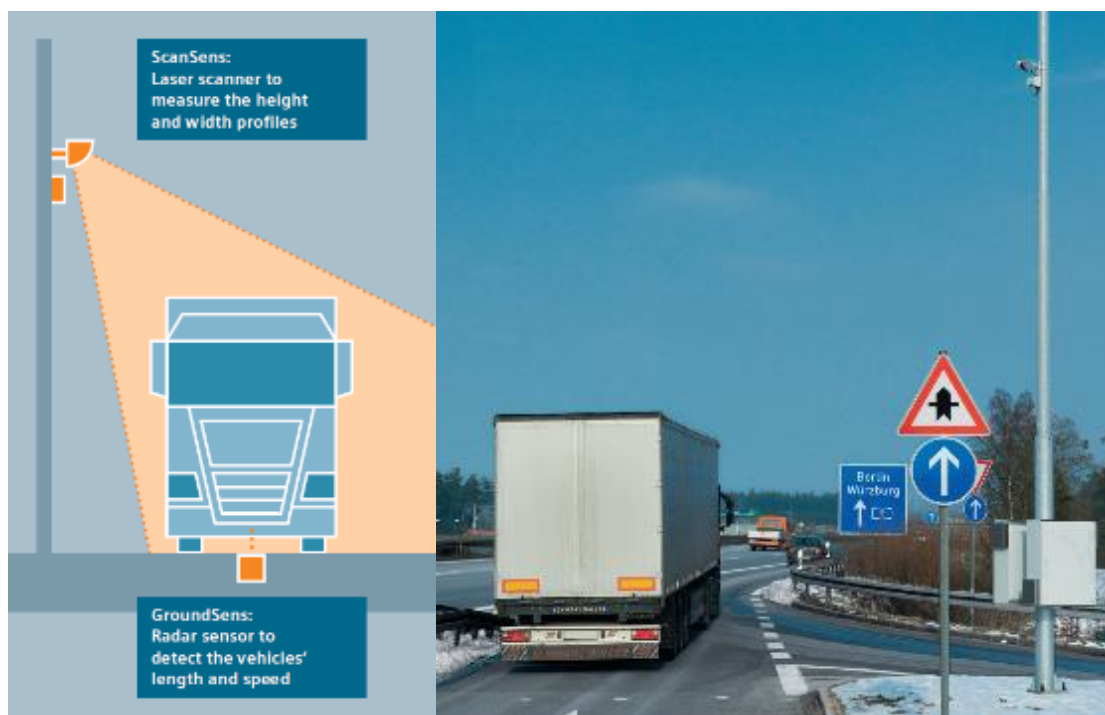
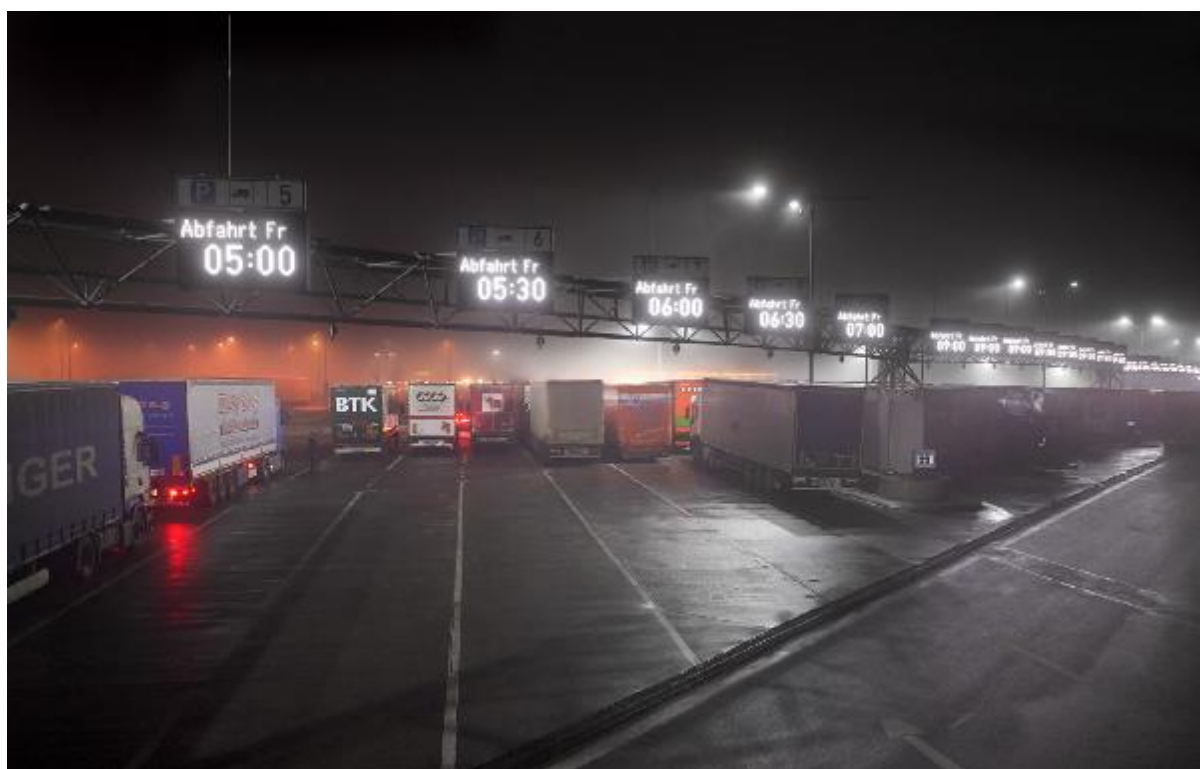

Figure 19: Detection and identification of truck at entry and exit



Figure 20: Detection of parking trucks by laser scanner

Other big ones are equipped with queue parking infrastructure, where the parking site has been restructured, parking lanes for three or more trucks have been marked and a terminal has been installed.



**Figure 21: Queue parking at Jura West**

The departure time for all trucks parked in that lane is indicated above. This allows a condensed parking as there are less feeding and emptying lanes required.

A pre-reservation is not possible for those parking sites. A second type of parking site is the Autohof. An Autohof is located at motorway interchange aside the motorway privately operated. As a matter of this a pre-reservation is possible.

There exist several digital platforms for booking and secure parking:

- Trucker-App,
- Truck Parking Europe listing different types of secure parking sites,
- Kravag Truck Parking App and
- Bosch Secure Truck Parking.

### 1.1.10 Parking Information

Parking information in Germany is currently handled in different ways. Since many years the federal state of Bavaria informs truck drivers about the current capacity via the BayernInfo homepage:

[Güterverkehr - BayernInfo](https://www.bayerninfo.de/de/parken?geo=48.27513,11.6426&zoom=15.6&traffic=false)

<https://www.bayerninfo.de/de/parken?geo=48.27513,11.6426&zoom=15.6&traffic=false>

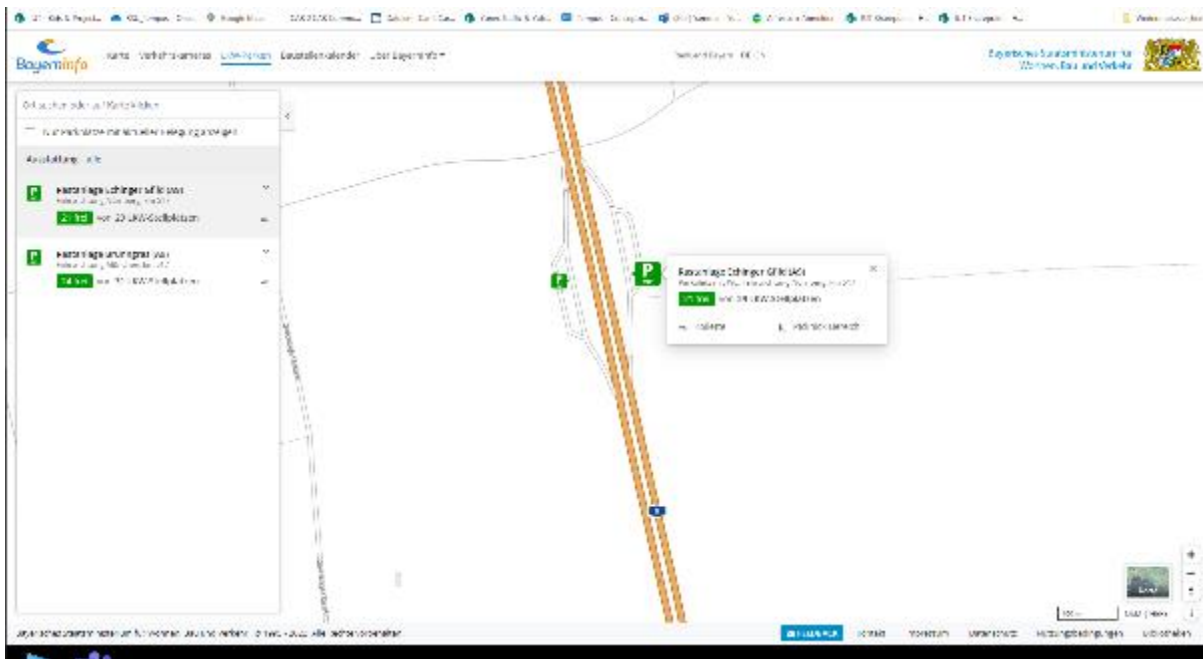

Figure 22: BayernInfo information on truck parking capacity on the A9 motorway

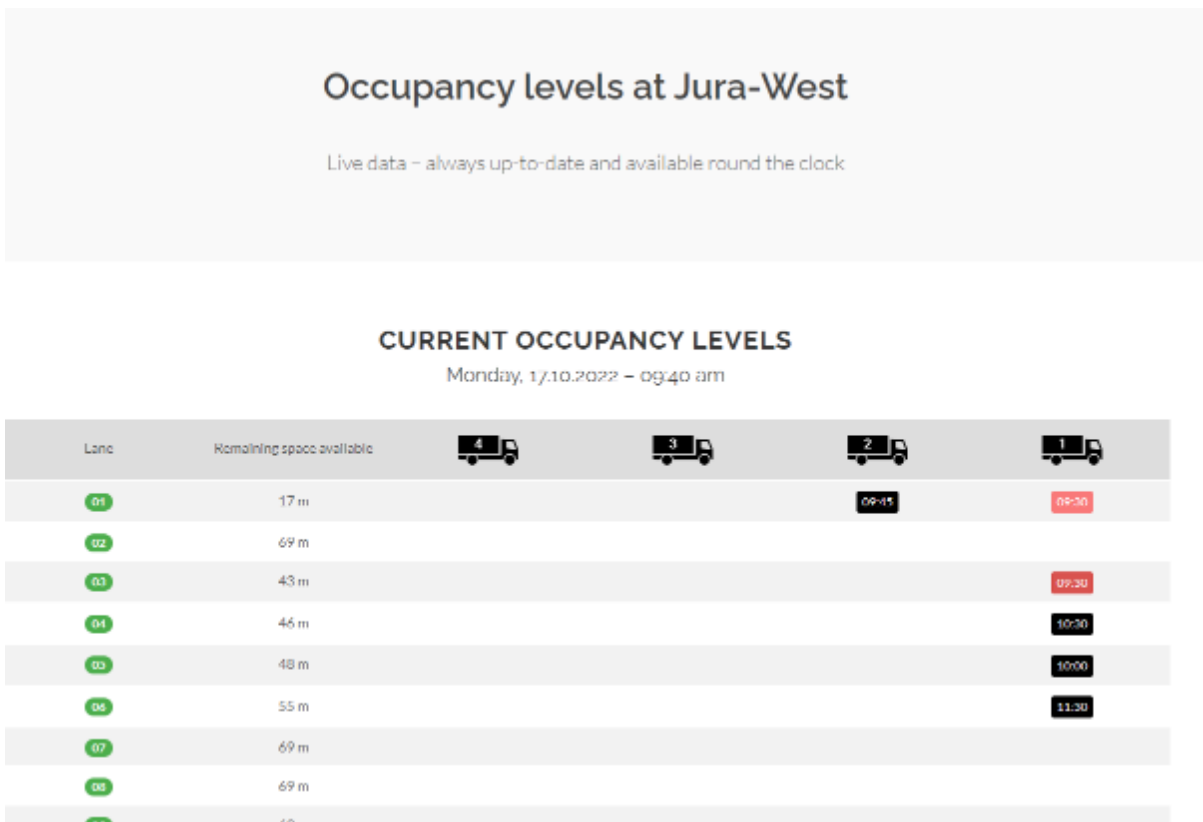

Figure 23: Occupancy of the parking lanes of a queue parking site

A new cooperation between the Toll Collect GmbH and the Bundesamt für Logistik und Mobilität [BMDV - Vertragsunterzeichnung im BMDV für neuen Stellplatzinformationsdienst](#)

[bund.de](http://bund.de) shall provide the capacity of parking sites based on data from the German truck tolling system. The planned SID-system will provide data via an open database called Mobilithek. Any service e.g. navigation services can use these data. It is planned that until mid of 2026 the information of about 1900 rest areas and parking sites will be available.

In some cases, the free capacity of a parking site for trucks is indicated on an upstream variable message sign. An example of the parking site Taunusblick on the A5 is shown in Figure 24.



**Figure 24: Example for the roadside information of free parking spaces for trucks in Germany**

A system to warn drivers entering a rest area or parking site has recently been installed in Germany (<https://www.autobahn.de/die-autobahn/aktuelles/detail/mehr-sicherheit-beim-einfahren-an-autobahn-rastanlagen>, 13.06.2024). The system detects vehicles which are dangerously parked at the entrance areas and warns drivers about the situation when leaving the motorway.



**Figure 25: Example for a system, warning drivers entering a rest area or parking site (Die Autobahn 2024)**

A new system was installed by the Autobahn GmbH on the A3 at the rest area Medenbach near Wiesbaden.

<https://www.eurotransport.de/artikel/lkw-stellplaetze-stellplatzdetektion-fuer-intelligentes-parken-gestartet-11210074.html>

This system scans via Laser the status of each parking lot and informs the truck driver via an App about free parking lots. The truck driver can use this information to easily find a free parking lot.

## 4.7 Greece

### 1.1.11 General Information

There is less information available about the truck parking situation in Greece. The Otra site [Greece \(weareotra.com\)](https://weareotra.com) lists 4 parking sites where parking spaces are bookable. The capacity ranges from 20 to 120 parking spaces.

Figure 26 shows the rest site Aerino on the A1 which offers secure parking. Secure parking sites offer a pre-booking.

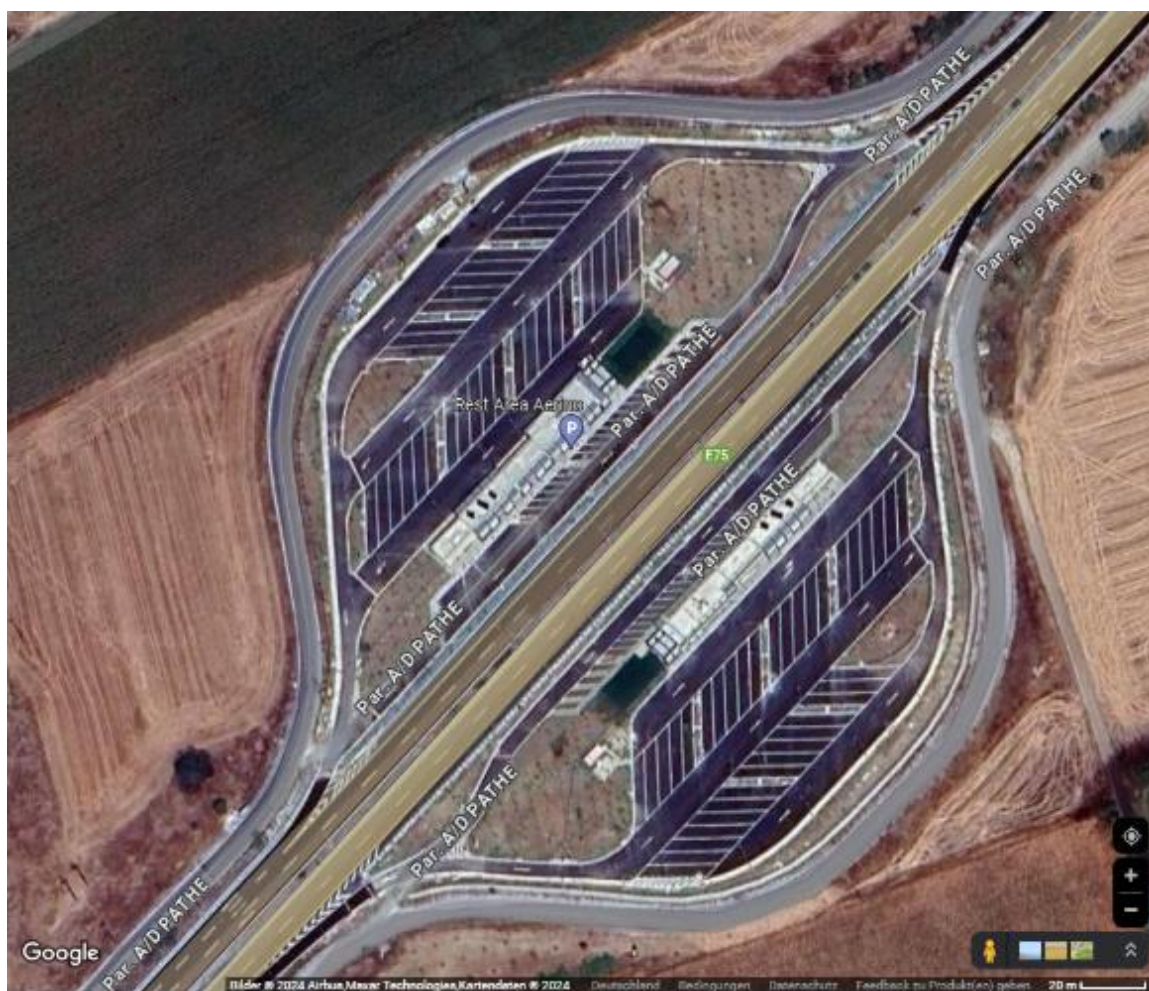

**Figure 26: Example for a secure parking site on the A1 in Greece**

Another secure parking site at the motorways Ionia Odos from Antirrio to Ioannia SSTP Episkopiko MSS- Branch to Egnatia.



Figure 27: A5 Ionia Odos motorway safe and secure truck parking Episkopiko

### 1.1.12 Parking Information

There is no information on roadside VMS for parking information.

## 4.8 The Netherlands

### 1.1.13 General Information

There are parking facilities along the motorways in The Netherlands with a spacing of approx. 20 km which can be used for a short stop (<https://www.rijkswaterstaat.nl/wegen/wegbeheer/parkeren-voor-vrachtwagenchauffeurs>). There might be the possibility to refuel, charge electrically or rest.

Truck drivers who want to rest for a longer period can go to secure private parking lots close to the highway. For that reason, the capacity of the motorway parking sites is limited. The rest areas for resting a longer time are currently overcrowded and parking in critical areas like shoulder lanes and ramps is often a problem and therefore is controlled by the road inspectors of Rijkswaterstaat. For that reason, there are activities going on to increase the number of parking spaces.

There are already private truck parking sites in many places. There are currently more than 50 registered commercial truck parks. In recent years, larger, secure truck parking lots have been realized, often with 200 or more parking spaces. Maasvlakte Plaza in Rotterdam (350 places) and Hazeldonk in Breda (200 places) are examples for secure truck parking.

The commercial parkings are considered too expensive, and not known to (foreign) truckers because the locations are off the motorway on industrial areas for example (e.g. <https://a1truckparkingdeventer.com/de/>)

In a webinar (in Dutch) , TLN (Transport Logistics NL) estimates that we have 10,000 parking places and need an additional 4400 (<https://www.tln.nl/actueel/tln-in-webinar-nt-enorm-tekort-aan-truckparkings-in-nederland>)

Maybe of interest is a new EU regulation on parking sites (2022): [https://eur-lex.europa.eu/eli/reg\\_del/2022/1012/oj](https://eur-lex.europa.eu/eli/reg_del/2022/1012/oj)

Truck parking seems more like an organisational problem rather than a communication problem. In the InterCor and C-Mobile projects it was achieved to set up use cases with Truck Parking Europe App (available in the play store), that shows available parking places all over Europe.



**Figure 28: A15 Parking site of smaller size**

Whereas small parking sites (Figure 28) can be found on motorways in The Netherlands, some parking sites (Figure 29) especially at the border to Germany are of bigger size.



Figure 29: A1 Parking site of bigger size

Some parking sites (Figure 30) show big green areas which easily can be converted into parking lots to increase the capacity. These parking



Figure 30: A1 Parking site of bigger size with big green parts

### 1.1.14 Parking Information

There is no information on roadside VMS for parking information.

## 4.9 Sweden

### 1.1.15 General Information

The Swedish Transport Administration has identified similar situations as occur in other European countries which negatively impact the accessibility and primary function of the parking sites and rest areas. This includes limited capacity of parking facilities, fully occupied rest areas (likely due to a combination of traffic volume and driving and rest regulations), detached trailers (while drivers continue their journeys), temporary settlements, and crimes targeting road users.

There are also sporadic occurrences of vandalism and fires. These phenomena can have negative consequences for traffic safety, maintenance, as well as comfort and security. There have even been instances where the Swedish Transport Administration has been forced to close a rest area.

To assess the current capacity status along the main road network a report has been prepared by the Swedish Transport Administration. This report also includes capacity of parking spaces at commercial facilities.

The map shows the number of parking spaces at the Swedish Transport Administration's rest areas suitable for truck parking along the main road network, as well as the number of parking spaces at inventoried commercial truck parking facilities.

The map presents the status for the year 2020 and is based on data from NVDB. Since the number of parking spaces is not always clearly defined and reported, the data from NVDB should be considered an estimate.

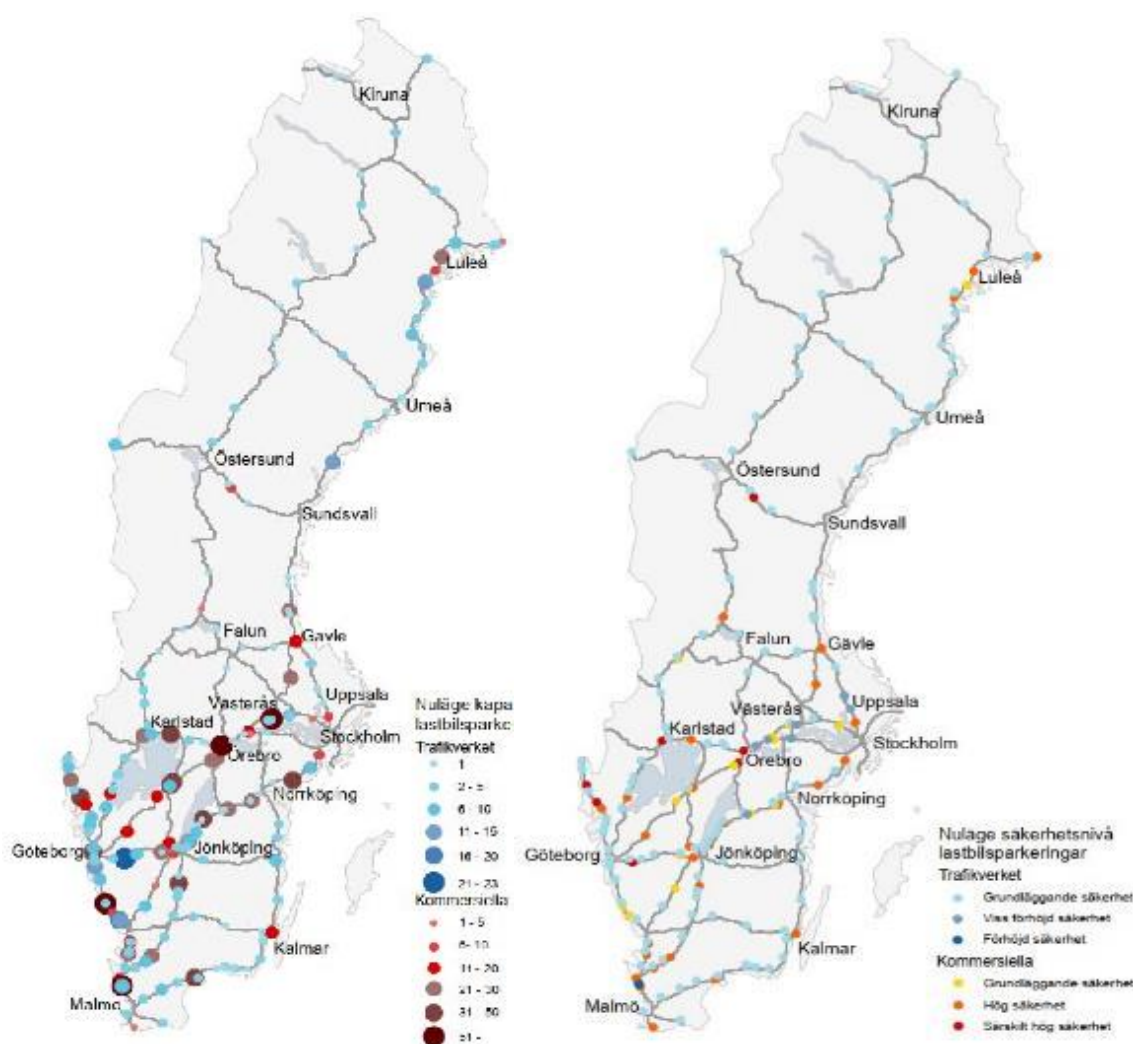

**Figure 31: A1 Plans showing commercial and federal parking sites (left) and sites with the need for further infrastructure (right)**

The Swedish Transport Administration is evaluating the need and the possibilities for further infrastructure, for example camera surveillance, smart lighting, capacity detection, and data and information management. This may also include pilot projects

Currently, there are two active pilot projects related to lighting and camera surveillance, as well as an upcoming project focused on capacity and detection. There are also plans to soon initiate a preliminary study aimed at connecting location-based and vehicle-based technology, which has the potential to result in another future pilot project.

At rest areas managed by the Swedish Transport Administration, it is not possible to reserve a parking spot. This would also conflict with the principles that the Swedish Transport

Administration operates under, which aim to make rest areas accessible to all road users. At private truck parking facilities, it may be possible to book a parking spot. This varies as different operators have different business models.

The Swedish Transport Administration assesses whether digital services can contribute to increasing safety and convenience in the transport system. Regarding truck parking, they see that the fundamental problem is that there are too few secure parking areas, especially around larger cities. Operators of commercial parking facilities describe that their sites are fully occupied every evening. A digital service cannot change that.

### 1.1.16 Parking Information

There is no information on roadside VMS for parking information.

## 4.10 Alternative Parking Solutions

### 1.1.17 KRAVAG Truck Parking

The insurance company KRAVAG offers a parking booking solution for all registered and paying logistic companies. The basic idea behind is that logistic companies open their premises for other drivers to park their truck after they have registered. This increases the overall number of truck parking locations and truck parking spaces. The truck drivers can use a web or mobile app for booking a parking space at the premises of another logistic company. With the same app the truck driver can get access to the premises and pay. The initiative is funded by the German Ministry of Transport. As a matter of fact the parking sites are located in some distance of the motorways and the regular truck routes.

<https://www.kravag-truck-parking.de>

Kravag Truck Parking is very active and has special options. However, it is just about Apps for normal existing parking sites, every week a new start-up pops up, e.g.

<https://lkw.app/>

and <https://www.truck-stops.com/>

### 1.1.18 OTRA Truck Parking

The OTRA Truck Parking system [OTRA Solutions - Guaranteed truck parking for truck drivers \(weareotra.com\)](https://weareotra.com) offers more than 170 parking sites in 18 European countries. It offers pre-booking, access and exit control systems and secure parking possibilities. The parking sites are often located at motorway interchanges in proximity of the motorway. It also offers real time occupancy information.

## 4.11 Types of detection

The provision of information for truck drivers requires the detection of the capacity of a parking site and of the location of free parking spaces. There are different types for the detection of occupied parking spaces.

---

## 1.1.19 Entrance and Exit Detection

Detection on parking sites on motorway started in Germany in 1990 by detecting the vehicles entrances and exits. This was not only counting, but the shape of the vehicle was detected to identify the vehicle at the entrance and again at the exit. This enables a balancing and finally the calculation of the current capacity. Unfortunately, the systems suffered of some detection errors.

1. Parking trucks in the detection area led to confusing results.
2. Mismatch of the entrance and exit shapes led to wrong counting.

Due to these facts this type of detector is currently not any more implemented.

## 1.1.20 Area detection

Area detection is the current preferred technology the detection of the capacity. Area detection is using cameras or LIDAR technology placed on a pole. For covering larger areas one detector is sufficient.

## 1.1.21 Single space detection

Single space detection is mainly uses in park houses to clearly indicate the approaching vehicles that a parking space is free or occupied.

Magnet field sensors in the ground are used for this purpose. They report the individual occupancy wireless to some local stations. A disadvantage is that each detector is inserted in the ground. They are equipped with a battery which has enough capacity for 10 years of operation.

---

## 5 Standards and Regulations

---

In Europe the law related to the driving time of truck drivers is very strict. Once the truck driver has parked his truck as his driving time has expired, he will not move his truck to another position. Except he is forced by the police. In this case he will need a confirmation of the police for later control by officials.

Article 12 of the central law document is dealing with this situation: <https://eur-lex.europa.eu/legal-content/DE/TXT/?uri=celex%3A32006R0561>.

Besides the pure number of the truck parking spaces, there are additional rules and limitations for parking of trucks of a special kind:

- Area limitations for e.g. refrigerator trucks, dangerous goods, oversized trucks
- Temporal limitation for trucks (parking only during night-time)

All these above-mentioned facts are complicating the life of the truck drivers on their trip.

### 5.1 C-Roads

C-Roads has provided a draft document [9] including a general description of the objectives and benefits of truck parking. Two scenarios are mentioned which provide parking information.

### 5.2 ETSI

ETSI has provided several documents related to communication. Besides the general architecture [10] and general topics [2] special ETSI deliveries deal with parking messages ([5] and [8]).

## 6 Use Cases

The following chapters describe use cases of various kind with relation to truck parking processes, critical parking situations and dangerous events triggered by parking trucks. They are mainly related to safety, where some are directly addressing safety issues and others are supporting truck drivers and easing the parking process. This support will influence safety indirectly.

Assumptions:

1. In the case that parking spaces can freely be chosen but are limited in number, we assume that it is not possible to refuse parking of a truck driver with enough driving time who wants to park and prioritize a truck driver with less driving time.
2. If use cases are dealing with more than one parking site, the first implementation of the use case should consider only one parking site. At a later stage day 2 use cases should consider more parking sites and the individual situation of the truck driver (e.g. driving time).
3. Individual services or uses cases requiring individual services like reservation and paying features are not considered in this document.
4. Day 1 use cases are mainly fixed so the use cases defined in this document are considered as day 2 use cases.

For a better structuring and comparison of the use cases identified, the template in Table 4 has been set up. It has been designed together with other groups of the C2C-CC defining use cases.

Descriptive use case name

ID	< UC_abc_00xyz >
Status	< Draft / Valid / Approved >
Priority	< urgent = 1 / ..... / less urgent, nice to have = 3 >
Deployment phase	< day 1 / day 2 / day 3+ / day x>
Roadmap, horizon	< near 1-2 years / mid-term 3-5 years / far future > 5 years >

Summary	< Brief description in one or two sentences >
Motivation	< Description of the rational for the use case >
Roles	e.g. <ul style="list-style-type: none"> <li>- truck,</li> <li>- other vehicle systems (e.g. GPS, tachograph)</li> <li>- truck driver,</li> </ul>

	<ul style="list-style-type: none"> <li>- local or central technical infrastructure,</li> <li>- national database server,</li> <li>- central C-ITS-subsystem,</li> <li>- roadside C-ITS-subsystem,</li> <li>- vehicle C-ITS-server,</li> <li>- service provider,</li> <li>- authority (as owner of local or central infrastructure)</li> </ul>
Description (incl. possible scenarios and desired outcome)	<p>Description of process, involved parties, communication, hardware requirements,</p> <p>Description of scenarios,</p> <p>Description of the expected behaviour of the system and the intended behaviour of the users</p>

Solution description

Data source	e.g. local detector (confidence level), central ITS sub-system, OBU, vehicle ITS sub-system, roadside ITS sub-system, GNSS; internet (e.g. reservation, freight planning), user input
Data sink, user	e.g., driver, central management system
C-ITS Messages	Messages between ITS-sub-systems CAM, DENM, IVIM, MAPM, POIM/POIM-PA
Prerequisites	Conditions that must be met, to prepare the initial environment for running this use case.
Penetration rate	Required number of trucks using C-ITS or are equipped with the necessary infrastructure to run the use case
Expected Benefit	<p>&lt; Safety / comfort / efficiency &gt;</p> <p>A description of the added value and actor benefits.</p>

**Table 4: Template for the description of a use case**

To visualize the involved entities and the process of information generation and information exchange, UML-diagrams have been defined for each use case.

The blue color identifies all parts involved which are not related to C-ITS. These are e.g. detection systems and/or the related servers. On the other side the driver and general devices of a truck like the navigation device are also not related to C-ITS. The interfaces in between these parts are often proprietary.

A black color identifies C-ITS related parts. This is the C-ITS server (S), the C-ITS roadside station (R) or the C-ITS vehicle equipment (V). The interfaces in between those parts are standardized via the messages CAM, DENM, IVIM, etc..

### 6.1 Use Case 1 ‘Free Capacity’ detected by infrastructure

This use case covers the provision of information about free parking spaces. This information is required by truck drivers approaching parking sites available on the different motorways downstream within a defined range. To know this number, it is required that all occupied parking spaces of a parking site are known, and the free capacity can be calculated. This use case handles the process where the infrastructure of the parking site can detect occupied parking spaces and provide the information about the current capacity via:

- a map, available through the internet,
- cooperative messages (considered in this use case),
- variable message signs on the upstream road section or
- via direction information at the entry of the parking site.

To ensure that the truck is only occupying one parking space, trucks exceeding the parking space and blocking another parking space, or the driveway (blocking entry or exit of other trucks) must be identified. These situations are covered by the use cases described in the chapters 6.4 and 6.5.

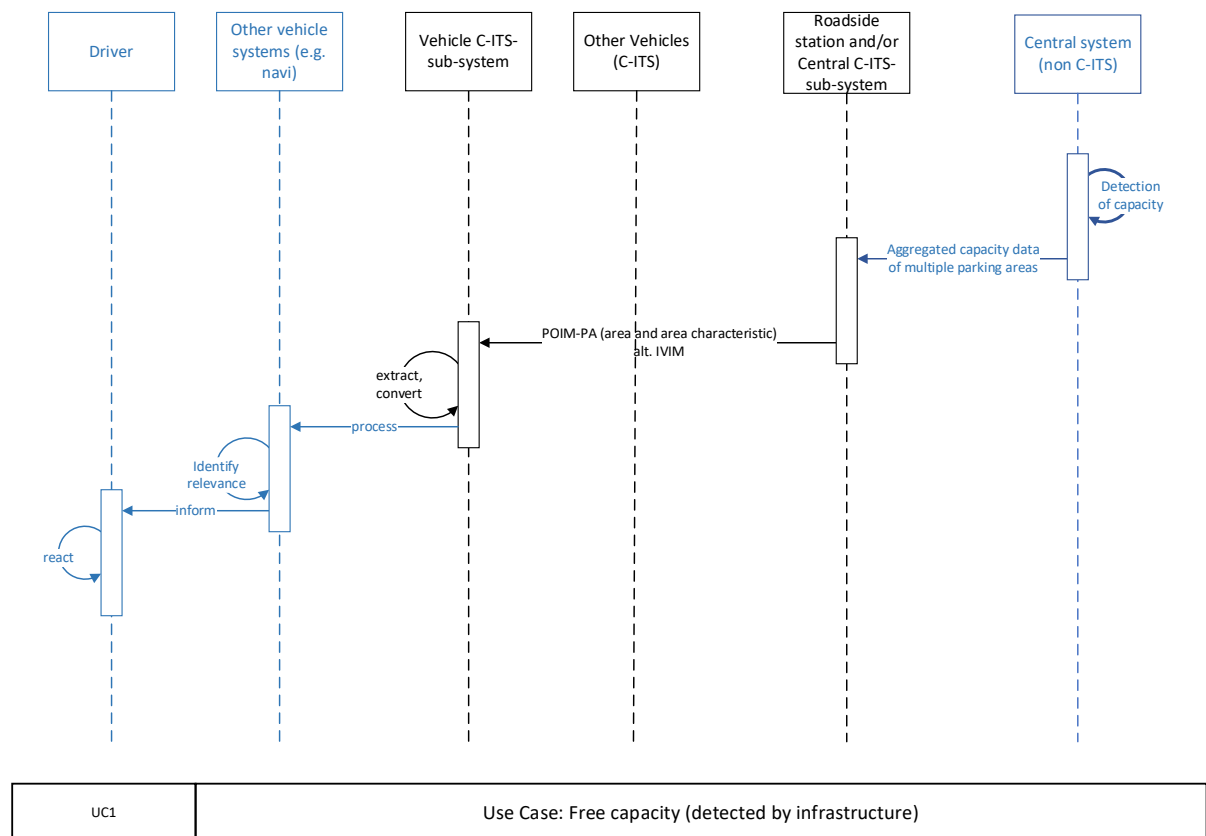

Figure 32: UML-sequence of use case 1

Free capacity detected by infrastructure (local detectors)

ID	UC_capacity_01
Status	Valid
Priority	2
Deployment phase	day x
Roadmap, horizon	mid-term 3-5 years

Summary	Information about the capacity of a parking site is detected by the infrastructure and distributed amongst the approaching trucks upstream the parking sites.
Motivation	Information on the capacity can improve the decision of the truck driver to look for a parking space in time, to find a parking space prior to the end of the allowed driving time and to prevent from parking at dangerous locations.
Roles	<ul style="list-style-type: none"> <li>- central management system using a detection system for the parked trucks and maybe has the capability to do a forecast (using standard time series of demand and capacity)</li> <li>- national database server (if available) collecting all parking information for distribution by service providers</li> <li>- central ITS sub-system</li> <li>- roadside ITS sub-system (approx. 4 km upstream)</li> <li>- vehicle ITS sub-system (at truck)</li> <li>- other vehicle systems</li> <li>- driver</li> </ul>
Description (incl. possible scenarios and desired outcome)	<ol style="list-style-type: none"> <li>1. The capacity of a parking site is detected by any kind of local detection at the parking site. The information of all parking sites can be collected in a national database (e.g. Mobilithek in Germany) and accessed and distributed by various services.</li> <li>2. The capacity is distributed at roads upstream the parking site via C-ITS messages. The capacity can be indicated via the percentage of free parking spaces. The capacity is distributed via C-ITS messages additional information like length of parking space or additional information can be added. The objective is to propose the capacity of the next two parking sites with relation to the route, capacity and left legal driving time of the truck driver. For the next parking site following a certain position on the motorway the current capacity shall be provided by the</li> </ol>

	<p>central management system. For the second next parking site the distance might make it necessary to consider the travel time and therefore to do a forecast of the capacity e.g. in steps of 15 minutes.</p> <ol style="list-style-type: none"> <li>3. The vehicle ITS-subsystem must provide a first selection of relevant parking sites. This filtering can be done using information available from vehicle devices like navigation device. Note: parking spaces can be classified according to additional infrastructure (charging infrastructure, power supply for refrigerators, limitations, dangerous goods,...). This feature is covered by other use cases as the focus here is the capacity. Parking spaces can be classified according to the station type<sup>1</sup> [11].</li> <li>4. The navigation device must select the parking sites which fit to the vehicle characteristic, route, driving time and forecasted capacity.</li> <li>5. The driver is informed about the results.</li> <li>6. Option: parking spaces are classified according to additional infrastructure (charging infrastructure, power supply for refrigerators, limitations....)</li> </ol>
--	--

Solution description

Data source	<p>Detector at parking site (confidence level),</p> <ul style="list-style-type: none"> <li>- balancing systems with lower confidence level</li> <li>- laser scanner with higher confidence level</li> </ul> <p>Detectors on motorway for travel time estimation.</p>
Data sink, user	driver
C-ITS Messages	<p>Preferred solution: POIM / POIM-PA</p> <p>Additional: official message from authority via IVIM free text, language</p>
Prerequisites	<ul style="list-style-type: none"> <li>- detection infrastructure at parking site with required accuracy,</li> <li>- possibility of the vehicle ITS-subsystem to access and communicate with other non-ITS vehicle subsystems (e.g. navigation device)</li> </ul>
Penetration rate	1 truck
Expected Benefit	<p>Efficiency: The truck driver will get the information of the capacity prior to entering the parking site. This will reduce inefficient cruising around looking for an empty space.</p>

<sup>1</sup> unknown(0), pedestrian(1), cyclist(2), moped(3), motorcycle(4), passengerCar(5), bus(6), lightTruck(7), heavyTruck(8), trailer(9), specialVehicles(10), tram(11), roadSideUnit(15)

	<p>Comfort: The truck driver will be able to early select a suitable parking site for his rest with respect to distance and capacity).</p> <p>Safety: Less manoeuvring and less parking in critical areas.</p>
--	--

Table 5: Description of use case 1

## 6.2 Use Case 2 ‘Free Capacity’ detected by geofence

This use case covers the provision of information about free parking spaces. This information is required by truck drivers approaching parking sites available on all motorways downstream within a defined range. To know this number, it is required that all occupied parking spaces of a parking site are known, and the free capacity can be calculated. This use case handles the process where the infrastructure of the parking site can detect occupied parking spaces and provide the information about the current capacity via:

- a map, available through the internet,
- cooperative messages (considered in this use case),
- variable message signs on the upstream road or
- via direction information at the entry of the parking site.

To ensure that the truck is only occupying one parking space, trucks exceeding the parking space and blocking another parking space, or the driveway (blocking entry or exit of other trucks) must be identified. These situations are covered by the use cases described in the chapters 6.4 and 6.5.

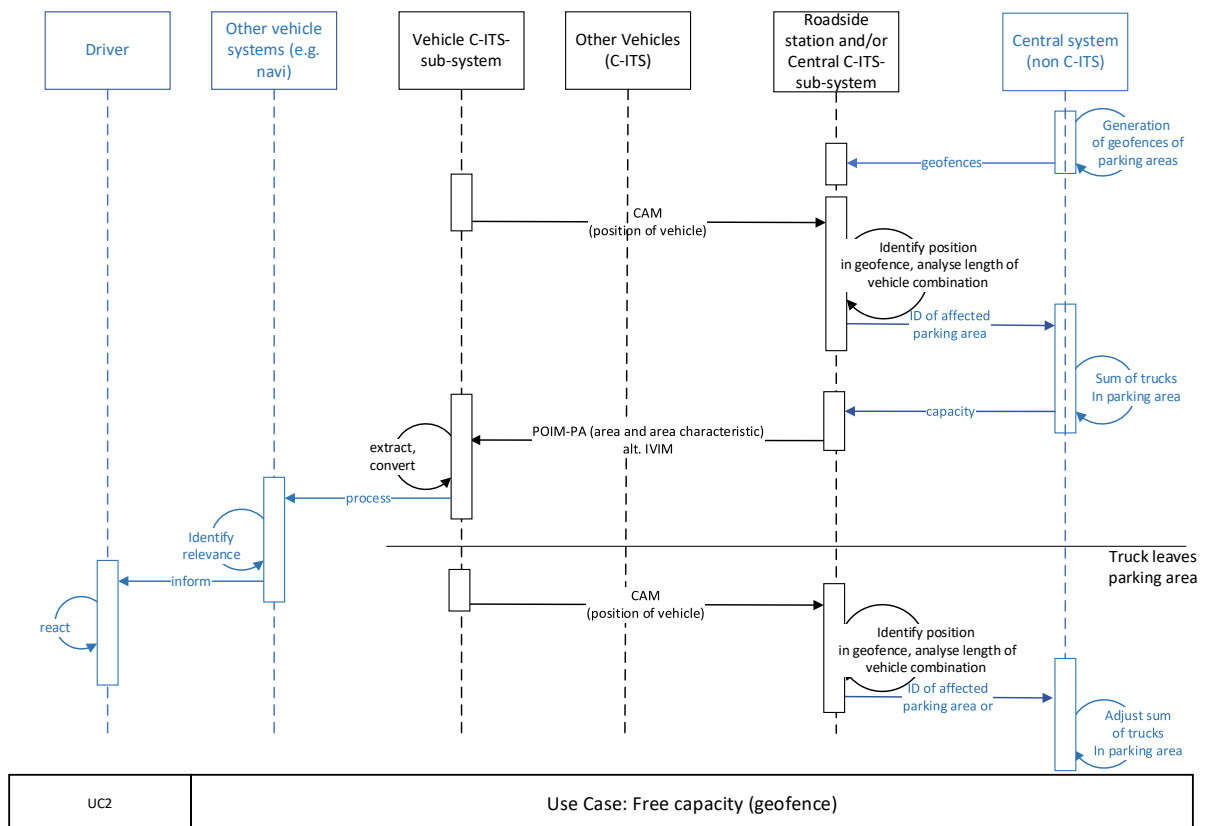

Figure 33: UML-sequence of use case 2

Free capacity detected by geofence

ID	UC_capacity_02
Status	Valid
Priority	2
Deployment phase	day x
Roadmap, horizon	far future > 5 years (100% of trucks must be equipped)

Summary	Information about the capacity of a parking site or area or place is detected by the occupancy of geofences and distributed amongst the approaching trucks.
Motivation	Information on the capacity can improve the decision of the truck driver to look for a parking space in time and to find a parking space prior to the end of the allowed driving time.
Roles	<ul style="list-style-type: none"> <li>- truck with GPS</li> <li>- vehicle ITS station</li> <li>- roadside ITS station</li> <li>- central ITS server with geofence decides on position of truck within geofence</li> </ul>
Description (incl. possible scenarios and desired outcome)	<ol style="list-style-type: none"> <li>1. The central ITS sub-system has geofence of parking area or of parking spaces.</li> <li>2. The vehicle reports its position.</li> <li>3. ITS-roadside station identifies position within geofence, and reports occupied ID of parking area or space. The parking area or space has specified characteristics.</li> <li>4. Central system counts vehicles inside the parking site or area, the occupancy/capacity is calculated and distributed together with the characteristics.</li> <li>5. The vehicle ITS-subsystem must provide a first selection of relevant parking areas or parking places which fit to the vehicle characteristic. Note: parking spaces can be classified according to additional infrastructure (charging infrastructure, power supply for refrigerators, limitations, dangerous goods,....). This feature is covered by other use cases as the focus here is the capacity. Parking spaces can be classified according to the station type<sup>2</sup> [11].</li> </ol>

<sup>2</sup> unknown(0), pedestrian(1), cyclist(2), moped(3), motorcycle(4), passengerCar(5), bus(6), lightTruck(7), heavyTruck(8), trailer(9), specialVehicles(10), tram(11), roadSideUnit(15)

	<ol style="list-style-type: none"> <li>6. The navigation device must select the parking areas which fit to the vehicle characteristic, route, driving time and forecasted capacity.</li> <li>7. The driver is informed about the results.</li> <li>8. The vehicle reports its position when leaving the parking site.</li> </ol>
--	--

Solution description

Data source	C-ITS truck
Data sink, user	driver
C-ITS Messages	POIM-PA for geofence, CAM/DENM, IVIM,
Prerequisites	<ul style="list-style-type: none"> <li>- requires improvements in the accuracy of the detection of the position</li> <li>- extended POIM-PA</li> </ul>
Penetration rate	100 % of trucks
Expected Benefit	<p>Efficiency: The truck driver will get the information of the capacity prior to entering the parking site. This will reduce inefficient cruising around looking for an empty space.</p> <p>Comfort: The truck driver will be able to early select a suitable parking site for his rest.</p> <p>Safety: Less maneuvering and less parking in critical areas.</p>

**Table 6: Description of use case 2**

### 6.3 Use Case 3 ‘Dangerous Parking Position’

Once the truck has reported his parking position a check must be conducted whether the truck is parked at an official position (type 1), a position which is not official but generally acceptable type 2) or a position where parking and stopping is forbidden in general (type 3). In the last case a message must be sent to the driver that he is currently parking at a location which is forbidden for parking.

The parking position is detected by infrastructure detectors.

The warning message either addresses the initiating vehicle or other drivers / vehicles approaching.

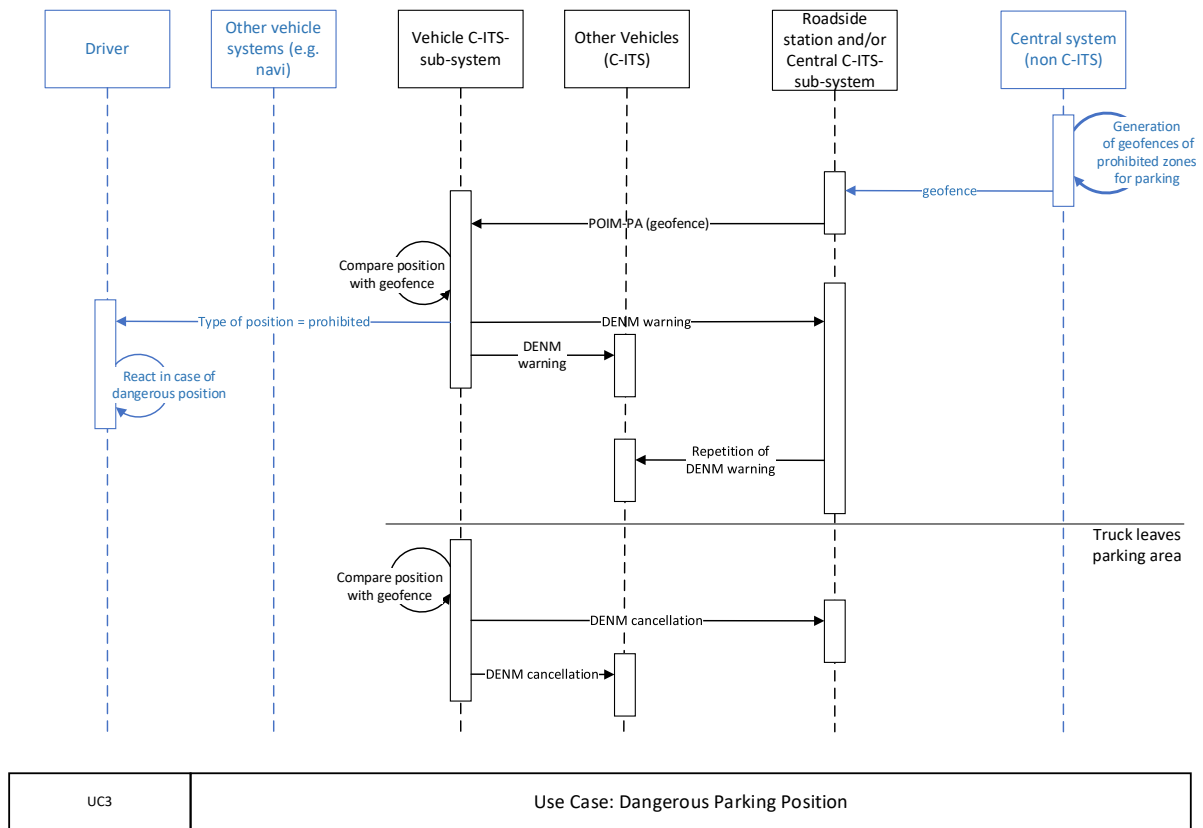

Figure 34: UML-sequence of use case 3

Dangerous parking position

ID	UC_parking_03
Status	Valid
Priority	1
Deployment phase	day x
Roadmap, horizon	mid-term 3-5 years

Summary	This use case checks the parking position of a truck. In case that a dangerous position (type 3) is identified the driver and other drivers are alerted.
Motivation	Reduce the number of accidents in overloaded parking sites
Roles	<ul style="list-style-type: none"> <li>- central ITS server with geofence</li> <li>- roadside ITS station</li> <li>- truck with GPS</li> <li>- vehicle ITS station, decides on position of truck within geofence</li> </ul>
Description (incl. possible scenarios and desired outcome)	<ol style="list-style-type: none"> <li>1. Characteristics and geofence of zones which shall not be used for parking (type 3) are communicated by infrastructure.</li> <li>2. Truck checks position and compares own position with the type 3 positions.</li> <li>3. Driver is informed about mismatch.</li> <li>4. Infrastructure is informed about mismatch.</li> <li>5. Other drivers are informed.</li> <li>6. When the truck leaves the critical position a cancellation DENM is sent.</li> </ol>

Solution description

Data source	Central system for parking site information, Truck for individual truck characteristics
Data sink, user	Truck driver, other drivers
C-ITS Messages	IVIM, POIM-PA maybe MAP for geofence, (from centre to vehicle) DENM (from vehicle to centre)
Prerequisites	The parking site needs to be classified into zones <ul style="list-style-type: none"> <li>- official parking zones (type 1),</li> <li>- no parking zone (critical as safety related) (type 2)</li> </ul>

	- other zone (parking not safety related) type 3)
Penetration rate	1 truck
Expected Benefit	Safety: prevent from crashes of moving and parking trucks

Table 7: Description of use case 3

### 6.4 Use Case 4 ‘Misuse of parking space (originated by truck)’

This use case deals with the topic of identifying and reacting on the situation where a vehicle is parking at a parking space which is not suited for it. Misuse is checked for the size and the type of the vehicle. The identification of the misuse of parking spaces or parking areas is a prerequisite for other use cases e.g. those dealing with the capacity.

There exist different cases where a vehicle is blocking a parking space or parking in a parking area which is not suited for the vehicle.

One case can be that a car with a trailer is blocking a truck parking space. As truck parking spaces are limited it is essential, that they are solely limited for trucks and not occupied by smaller vehicles.

Another case can be that a truck is using a parking space or parking area which is not suited for the truck as the area / space is limited for trucks of a special kind.

The following criteria or vehicle characteristics can be checked in this case:

- Vehicle length including trailer
- Load (dangerous goods, oversized)
- Type (diesel, electric)



Figure 35: Example of a truck occupying two parking spaces

Parking spaces can be classified according to the station type<sup>3</sup> [11].

This use case is covering the situation where the truck itself sends information which lets the system decide, that it is parked in the wrong position.

<sup>3</sup> unknown(0), pedestrian(1), cyclist(2), moped(3), motorcycle(4), passengerCar(5), bus(6), lightTruck(7), heavyTruck(8), trailer(9), specialVehicles(10), tram(11), roadSideUnit(15)

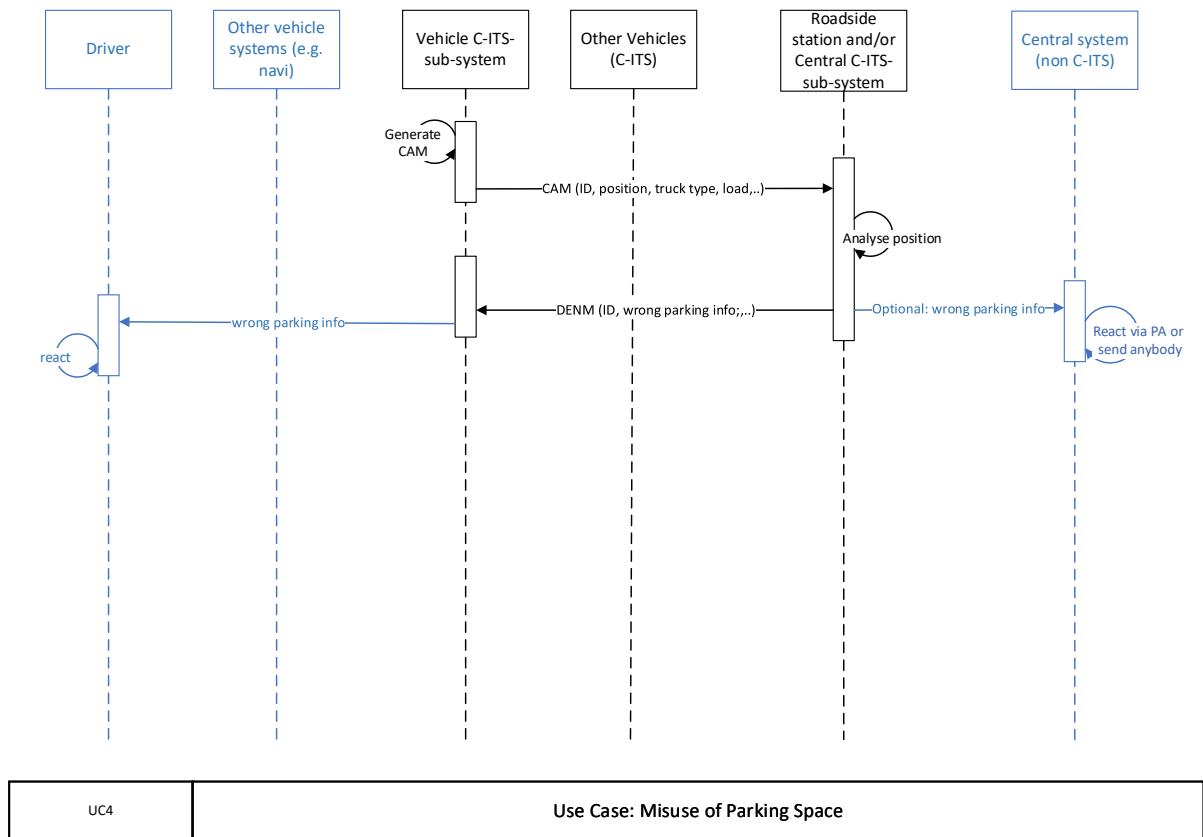

Figure 36: UML-sequence of use case 4

Misuse of parking space (originated by truck)

ID	UC_parking_04
Status	Valid
Priority	2
Deployment phase	day x
Roadmap, horizon	mid-term 3-5 years

Summary	Identification and alerting the driver of a vehicle if the vehicle is parked in a parking area or parking space which does not fit to the type or extension of the vehicle.
Motivation	Prevention of the blockage of a parking area or space by a truck or other vehicle which is not fit to the criteria if that area or space.
Roles	<ul style="list-style-type: none"> <li>- truck with vehicle ITS sub-system</li> <li>- roadside ITS sub-system</li> <li>- central ITS sub-system</li> <li>- truck driver</li> <li>- parking attendant, authority</li> </ul>
Description (incl. possible scenarios and desired outcome)	<ol style="list-style-type: none"> <li>1. The truck sends CAMs with initial information (vehicle characteristics and position). The infrastructure analyses the contents of the CAM i.e. position data, vehicle type, vehicle spacing and identifies whether the vehicle is parked in the appropriate area or space.</li> <li>2. Infrastructure is detecting that the vehicle does not fit to the type of parking area or space e.g. that a vehicle which is too short is blocking a larger parking area or space or a gravel truck is blocking the parking space for refrigerator trucks.</li> <li>3. Infrastructure sends information             <ol style="list-style-type: none"> <li>a. via public announcement PA (multicast), (problem: difficult because license plate is unknown)</li> <li>b. send somebody to the truck (manual), inform authority (manual), (problem: personnel is required)</li> <li>c. If the ID of the vehicle is available and the vehicle is still online a DENM can be sent via selective communication channel (peer-to-peer), unicast communication (automatic), (problem: anonymization of CAMs hinders the direct addressing of the vehicle)</li> </ol> </li> </ol>

Solution description

Data source	Truck (vehicle)
Data sink, user	Driver, infrastructure officials, staff
C-ITS Messages	POIM-PA, CAM, DENM
Prerequisites	<ul style="list-style-type: none"> <li>- extended POIM-PA is available</li> <li>- geofences for parking areas or parking spaces are configured and available</li> </ul>
Penetration rate	1 vehicle
Expected Benefit	Efficiency: parking site is optimally used

Table 8: Description of use case 4

### 6.5 Use Case 5 ‘Misuse of parking space (originated by infrastructure)’

This use case has the same objective as the previous one in chapter 6.4, but uses another principle for detection.

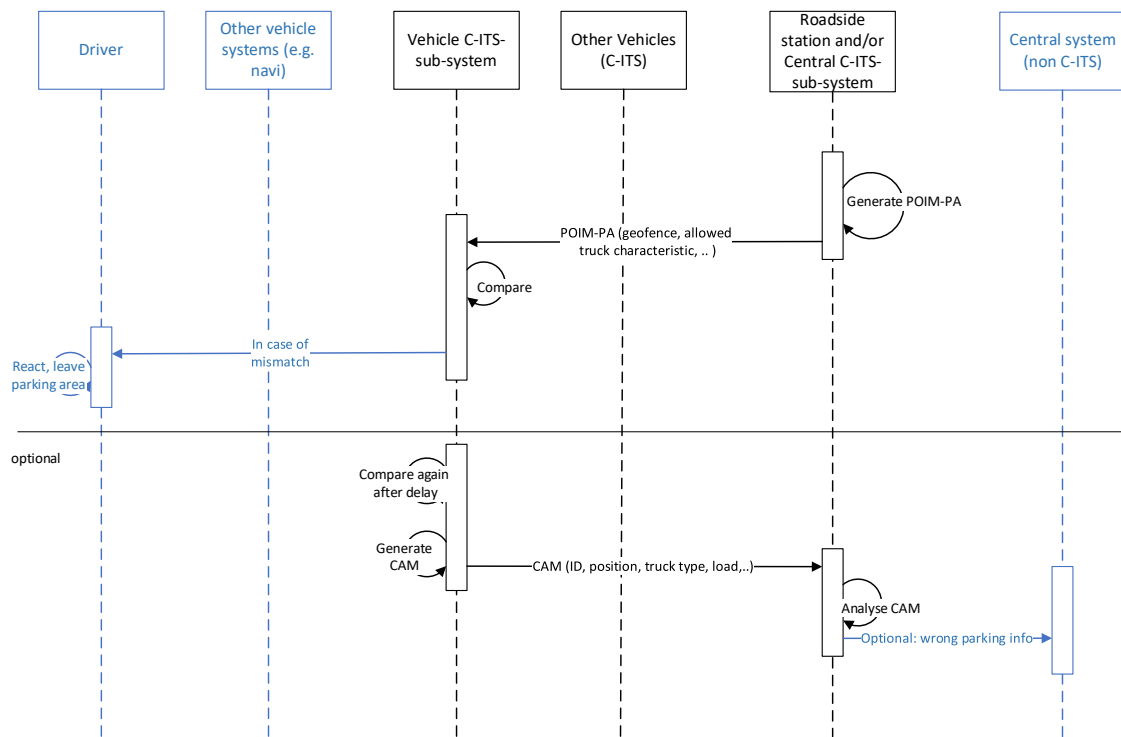

UCS	Use Case: Misuse of Parking Space
-----	-----------------------------------

Figure 37: UML-sequence of use case 5

Misuse of parking space (originated by infrastructure)

ID	UC_parking_05
Status	Valid
Priority	2
Deployment phase	day x
Roadmap, horizon	mid-term 3-5 years

Summary	Identification and alerting the driver of a vehicle if the vehicle is parked in an area which does not fit to the type or extension of the vehicle.
Motivation	Prevention of the blockage of a parking area or space by a truck or other vehicle which is not fit to the criteria if that area or space.
Roles	<ul style="list-style-type: none"> <li>- central ITS sub-system</li> <li>- roadside ITS sub-system</li> <li>- vehicle ITS sub-system</li> <li>- truck driver</li> <li>- parking attendant, authority</li> </ul>
Description (incl. possible scenarios and desired outcome)	<ol style="list-style-type: none"> <li>1. The infrastructure sends initial information (allowed vehicle characteristics in geofences) to the trucks</li> <li>2. Central system sends POIM-PA with geofence and area characteristics.</li> <li>3. Truck receives POIM-PA with the information of all geofences of a parking site which vehicle-characteristics are allowed to park in the defined parking areas or parking spaces. Information for the driver.</li> <li>4. Truck compares its position and characteristics with the received information.</li> <li>5. In the case that the truck is parked at the suited parking area or space the process ends.</li> <li>6. In the case that the vehicle is not parked at the suited area or space the driver can be alerted if an HMI is available.</li> <li>7. Optional: If the driver is neglecting the information after some delay a message (type unknown) is automatically sent to the infrastructure.</li> </ol>

Solution description

Data source	infrastructure, truck
Data sink, user	driver
C-ITS Messages	IVI, POIM-PA, CAM, DENM

Prerequisites	- extended POIM-PA is available
Penetration rate	1 vehicle
Expected Benefit	Efficiency: parking space is optimally used Safety:

**Table 9: Description of use case 5**

Parking spaces can be classified according to the station type<sup>4</sup> [11].

### 6.6 Use Case 6 ‘Dangerous parking’ (outside official parking infrastructure)

The parking of trucks in critical areas along the motorway (emergency lay by / shoulder lane /any restricted area of the motorway) is quite common as official parking spaces are limited. This use case deals with the detection of those situations and the warning of other vehicles.

The criteria for detecting a stationary vehicle and triggering a DENM can be used as a basis for this use case. There must be a differentiation to a ‘Stationary Vehicle’ DENM. It is therefore required to extend the conditions by additional cause codes for parking and no hazard lights activated and engine is stopped to specify the difference to a break down vehicle or a normal stopped vehicle (with hazard lights). The objective is to detect a parking vehicle with close distance to moving traffic.

A basic requirement for this uses case is a list of unsafe locations along a motorway which can be used for the definition of geo-fences.

The message should be valid as long as the vehicle is parked, but due to restrictions of power supply probably the period is limited.

---

<sup>4</sup> unknown(0), pedestrian(1), cyclist(2), moped(3), motorcycle(4), passengerCar(5), bus(6), lightTruck(7), heavyTruck(8), trailer(9), specialVehicles(10), tram(11), roadSideUnit(15)

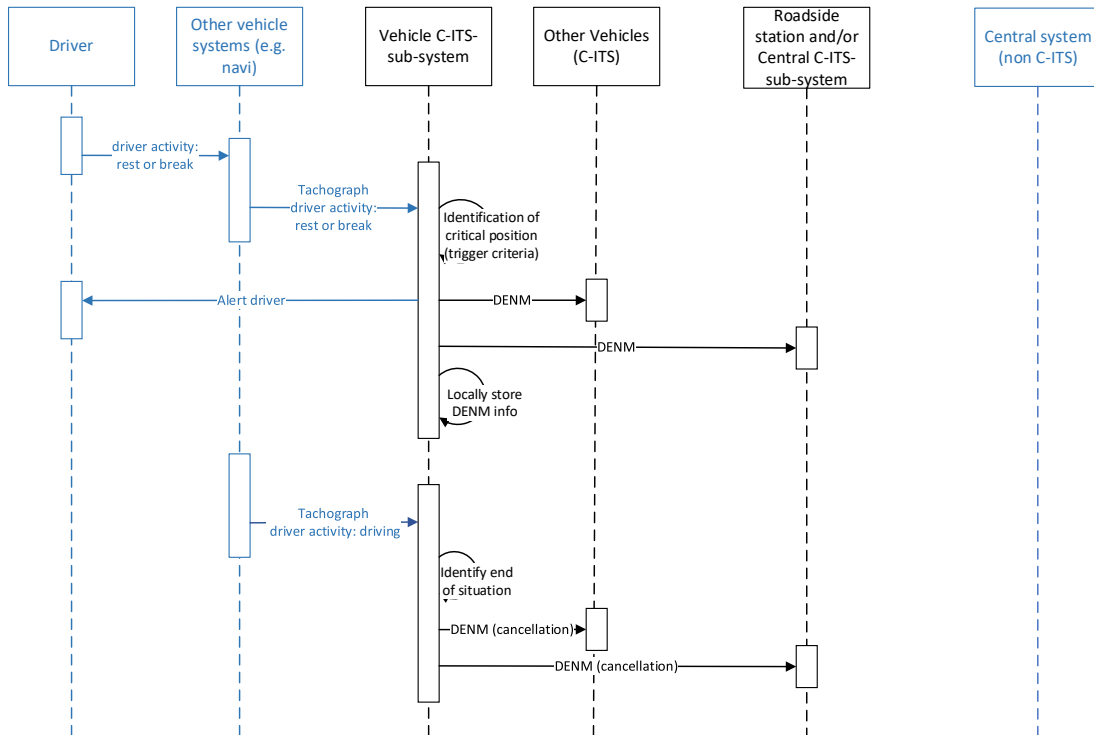

UC6	Use Case: Dangerous parking (outside official parking infrastructure)
-----	---

**Figure 38: UML-sequence of use case 6**

Dangerous parking (outside official infrastructure, detection by vehicle)

ID	UC_parking_06
Status	Valid
Priority	1
Deployment phase	day x
Roadmap, horizon	mid-term 3-5 years

Summary	This use case checks the parking position of a truck outside official parking areas e.g. on the motorway or in emergency lay-bys of a motorway. In case that a dangerous position is identified the driver, and other drivers are alerted.
Motivation	Reduce the number of accidents due to wild parking.
Roles	<ul style="list-style-type: none"> <li>- dig. tachograph</li> <li>- truck with vehicle ITS sub-system</li> <li>- roadside ITS subsystem</li> <li>- central ITS-subsystem</li> <li>- other drivers upstream</li> </ul>
Description (incl. possible scenarios and desired outcome)	<ol style="list-style-type: none"> <li>1. The vehicle parks at a location outside an official parking area close to the used lanes e.g. emergency lay-by. Criteria for triggering the message:                         <ol style="list-style-type: none"> <li>a. No hazard light,</li> <li>b. Tachograph information (driver activity: rest or break),</li> <li>c. Position of vehicle close to used lanes &lt; x meters. X tbd.</li> <li>d. The automatic transmission (AUT) is set to 'park' for at least 3 sec;</li> <li>e. The gear box is set to idle for at least 3 s.</li> <li>f. The parking brake is enabled for at least 3 s.</li> <li>g. In the vicinity vehicles drive with a delta speed of &gt; 10 km/h.</li> <li>h. Path history similar to paths of moving vehicles (parallel) to exclude e.g. bridge situations.</li> <li>i. No physical barrier is between parked vehicle and moving traffic.</li> </ol> </li> <li>2. The dig. tachograph indicates that a break is due, or a break is indicated (this criterion can be used to identify the validity time of the message).</li> <li>3. The driver can be alerted if an HMI is available.</li> </ol>

	4. The infrastructure sends DENMs to warn the upstream drivers.
Solution description	
Data source	truck
Data sink, user	Driver, drivers of any approaching traffic participants
C-ITS Messages	DENM
Prerequisites	Check whether the defined criteria for triggering provide a sufficient quality. Align criteria with similar use cases e.g. stationary vehicle
Penetration rate	1 vehicle
Expected Benefit	Safety: to prevent from crashes of parking and moving trucks / vehicles

Table 10: Description of use case 6

### 6.7 Use Case 7 ‘Dangerous parking’ (outside official parking infrastructure)

This use case is similar to the use case described in chapter 6.6 except that the way of detection is done by roadside infrastructure.

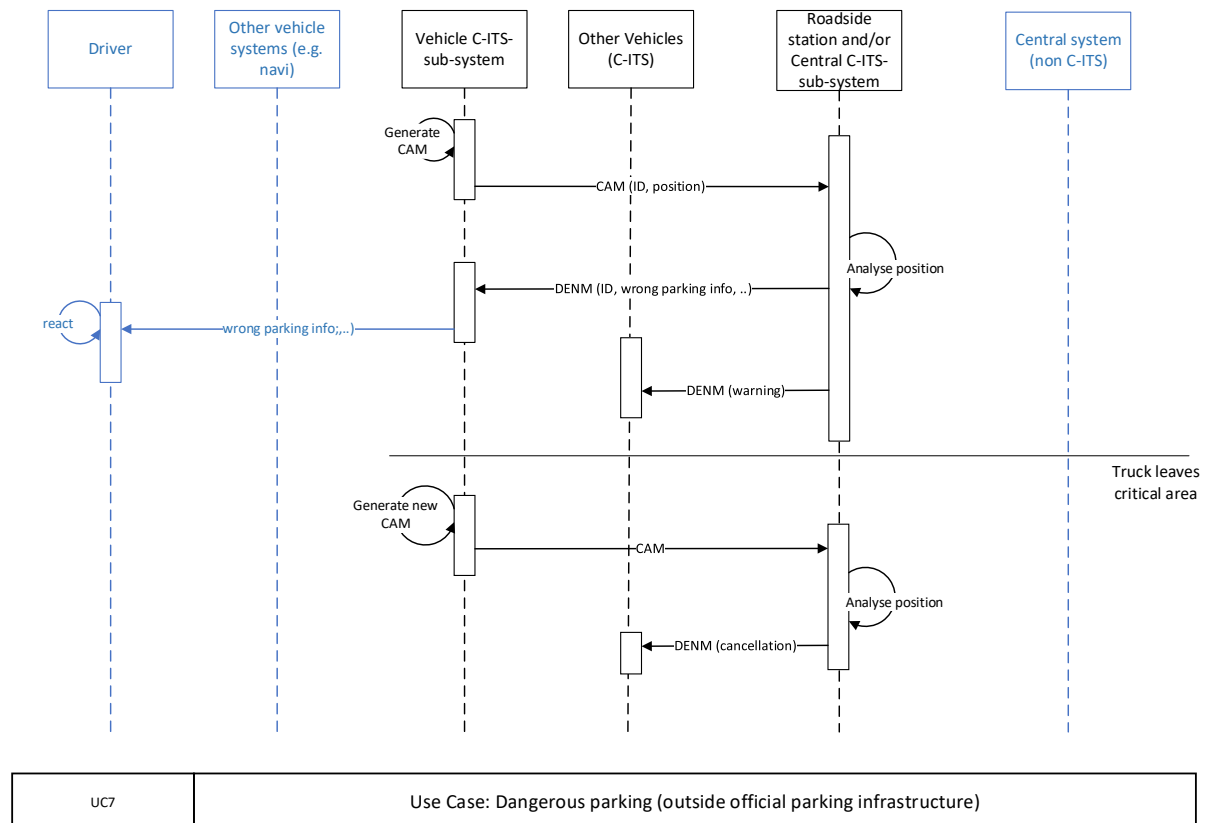

Figure 39: UML-sequence of use case 7

Dangerous parking (outside official infrastructure, detection by infrastructure)

ID	UC_parking_07
Status	Valid
Priority	2
Deployment phase	day x
Roadmap, horizon	mid-term 3-5 years

Summary	This use case checks the parking position of a truck outside official parking areas e.g. on the motorway or in emergency lay-bys of a motorway. In case that a dangerous position is identified the driver and other drivers are alerted.
Motivation	Reduce the number of accidents due to wild parking.
Roles	<ul style="list-style-type: none"> <li>- central ITS sub-system</li> <li>- roadside ITS sub-system</li> <li>- vehicle ITS sub-system</li> </ul>
Description (incl. possible scenarios and desired outcome)	<p>Detection by infrastructure</p> <ol style="list-style-type: none"> <li>1. Vehicles sends CAM with position data to infrastructure or other infrastructure like CCTV camera detects the vehicle.</li> <li>2. Infrastructure identifies that last position/vehicle is located in a critical area. Critical areas can be identified by geofences.</li> <li>3. If the ID of the vehicle is available and the vehicle is still online a DENM can be sent via selective communication channel (peer-to-peer), unicast communication (automatic),</li> <li>4. The infrastructure sends DENMs to warn the upstream drivers</li> </ol> <p>The driver can be alerted if an HMI is available</p>

Solution description

Data source	Vehicle position)
Data sink, user	Driver of ego-vehicle, drivers of any approaching traffic participants
C-ITS Messages	CAM, DENM
Prerequisites	<ul style="list-style-type: none"> <li>- Critical areas are available via geofences</li> </ul>
Penetration rate	1 vehicle

Expected Benefit	Safety: to prevent from crashes of parking and moving trucks / vehicles
------------------	---

**Table 11: Description of use case 7**

Far future variations of the use case:

- GNSS plus HD-maps (far future),
- Vehicle camera with AI can decide on the position, not for ordinary trucks, only available for autonomous vehicles (far future)

### 6.8 Use Case 8 ‘Departure Time’ (truck in right lane)

This use case is related to those parking sites where queue parking is applied. At queue parking sites the trucks are densely packed in rows where all trucks of one row share the same departure time. When entering the parking area, the truck driver provides actively or passively the information of his departure time. This information can be used by queue parking systems to indicate the lane the truck should be parked. The queue parking system can open new lanes or close lanes which are completely occupied.

The tachograph or the relevant on board device is managing the driving and the resting times. This defines the earliest legal departure time. Due to other influences (e.g. slots at terminals) the departure time can be prolonged. This requires the possibility and a UI for a manual input / correction of the departure time. Also, a link to the vehicle ITS sub-system has to be established to exchange this information. This system is currently not available.

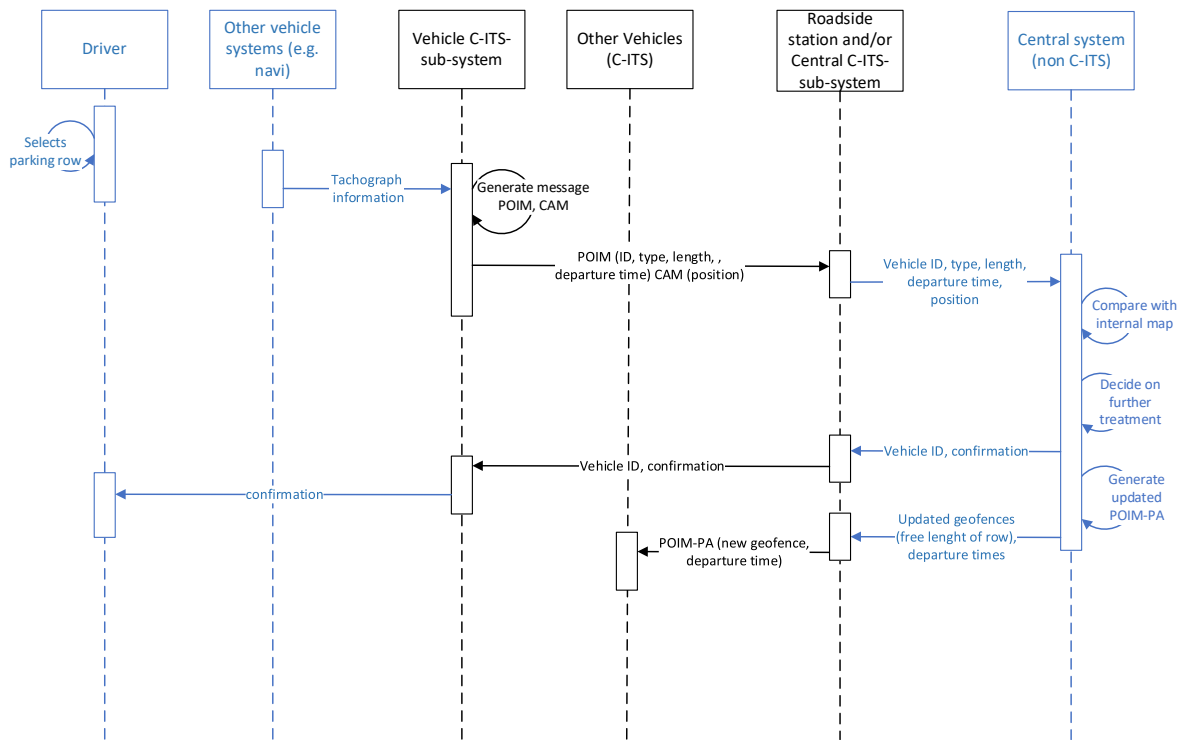

UC8	Use Case: Departure Time (infrastructure) Subcase truck has entered the right lane
-----	--

Figure 40: UML-sequence of use case 8

Departure Time (truck in right lane)

ID	UC_parking_08
Status	Valid
Priority	2
Deployment phase	day x
Roadmap, horizon	mid-term 3-5 years

Summary	The new concept of parking called compact parking requires the exact selection of the parking row according to the departure time. This use case checks of the departure time and the row and gives a feedback to the driver.
Motivation	Ensure that the truck has selected the right row.
Roles	<ul style="list-style-type: none"> <li>- central management system for parking</li> <li>- central ITS sub-system</li> <li>- roadside ITS sub-system</li> <li>- vehicle ITS sub-system</li> </ul>
Description (incl. possible scenarios and desired outcome)	<ol style="list-style-type: none"> <li>1. The departure time is indicated above the row. The driver enters the parking site and enters a parking row according to his departure time.</li> <li>2. The vehicle sends CAMs and the information of its departure time (POIM).</li> <li>3. The central system (non-C-ITS) compares this information with its internal map and the departure times related to the row.</li> <li>4. In case that the vehicle has entered the right row a confirmation message is sent as feedback to the truck.</li> <li>5. An update of the capacity of each row is made and distributed to all approaching trucks.</li> </ol>

Solution description

Data source	Truck
Data sink, user	The EGO truck driver, other truck drivers
C-ITS Messages	POIM, POIM-PA, CAM
Prerequisites	<ul style="list-style-type: none"> <li>- extended POIM-PA</li> <li>- information exchange between tachograph and vehicle ITS-subsystem</li> </ul>

Penetration rate	Works with the first vehicle but full benefit will be reached with 100 % equipped trucks
Expected Benefit	Efficiency:

Table 12: Description of use case 8

### 6.9 Use Case 9 ‘Departure Time’ (truck in wrong lane)

This use case is like the use case described in chapter 6.8 with the difference that the truck driver has chosen the wrong lane for parking.

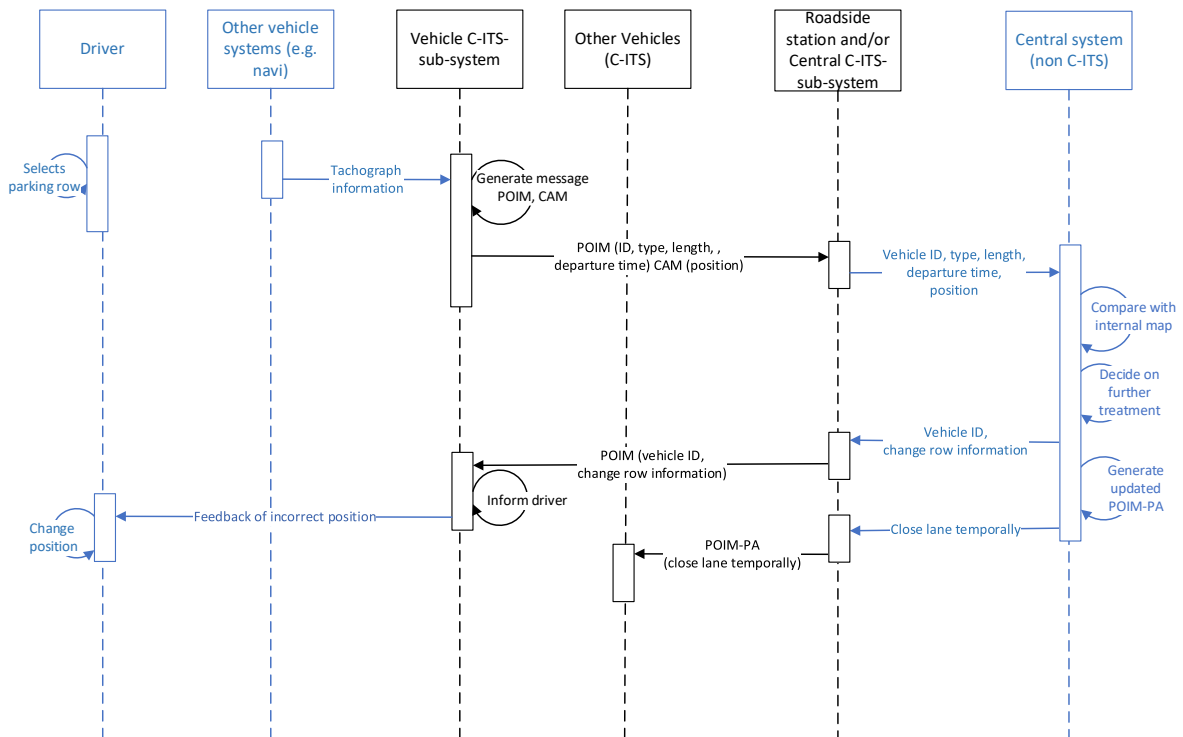

UC9	Use Case: Departure Time (infrastructure) Subcase truck has entered the wrong lane
-----	--

Figure 41: UML-sequence of use case 9

Departure Time (truck in wrong lane)

ID	UC_parking_09
Status	Valid
Priority	2
Deployment phase	day x
Roadmap, horizon	mid-term 3-5 years horizon depends on the availability of the vehicle infrastructure to adjust the departure time if different from the

Summary	The new concept of parking called compact parking requires the exact selection of the parking row according to the departure time. This UC handles the check of the departure time and the information distribution.
Motivation	Ensure that the truck has selected the right row.
Roles	<ul style="list-style-type: none"> <li>- central management system for parking</li> <li>- central ITS sub-system</li> <li>- roadside ITS sub-system</li> <li>- vehicle ITS sub-system</li> </ul>
Description (incl. possible scenarios and desired outcome)	<ol style="list-style-type: none"> <li>1. The departure time is indicated above the row. The driver enters the parking site and enters a parking row according to his departure time.</li> <li>2. The vehicle sends CAMs and the information of its departure time (POIM).</li> <li>3. The central system (non-C-ITS) compares this information with its internal map and the departure times related to the row.</li> <li>4. In case that the vehicle has entered the right row a confirmation message is sent as feedback to the truck.</li> <li>5. An update of the capacity of each row is made and distributed to all approaching trucks.</li> </ol>

Solution description

Data source	truck
Data sink, user	The EGO truck driver, other truck drivers
C-ITS Messages	POIM-PA, CAM
Prerequisites	- extended POIM-PA
Penetration rate	Works with the first vehicle but full benefit will be reached with 100 % equipped trucks

Expected Benefit	Efficiency:
	Comfort:

Table 13: Description of use case 9

### 6.10 Use Case 10 ‘Guidance to free parking place’ (list+map)

This use case is intended to ease the process of finding a free parking space, especially during those times where only few empty spaces are available amongst occupied ones. Once he has entered the parking area the truck driver is guided to a free parking space.

If the position is known the information can be put into a MAP message if possible. This would require an accurate detection.

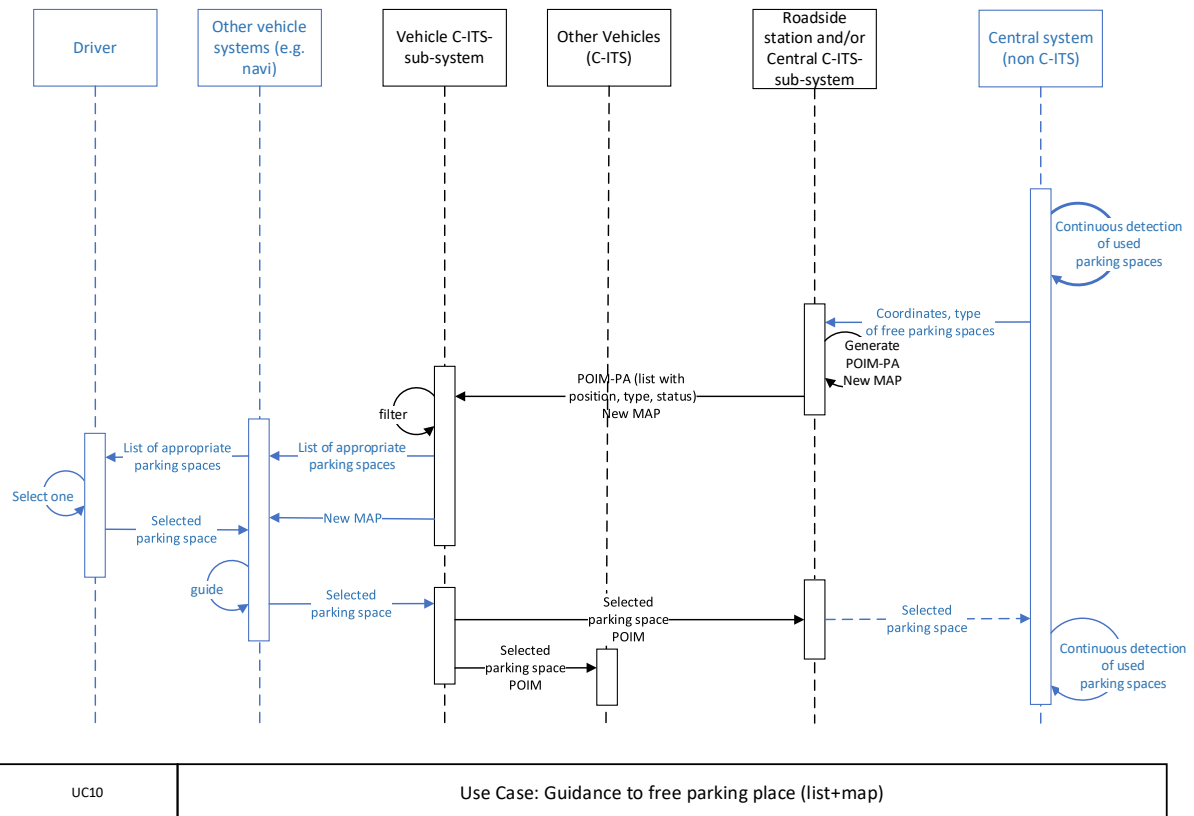



Figure 42: UML-sequence of use case 10

Guidance to free parking space (list+map)

ID	UC_guidance_10
Status	Valid
Priority	2
Deployment phase	day x
Roadmap, horizon	mid-term 3-5 years

Summary	This use case is about the optimum and safe guidance of the truck on the parking site to a free parking space which is suited for this type of truck.
Motivation	To show the optimum way, to prevent from cruising around and manoeuvring.
Roles	<ul style="list-style-type: none"> <li>- central management system for parking and detection</li> <li>- central ITS sub-system</li> <li>- roadside ITS sub-system</li> <li>- vehicle ITS sub-system</li> </ul>
Description (incl. possible scenarios and desired outcome)	<ol style="list-style-type: none"> <li>1. The detection system of the parking site identifies the occupied and free parking spaces. The infrastructure generates a map of all free parking spaces with a classification of the type (status (free, reserved, ...), suited for short / long trucks, power supply, limited for non-dangerous goods vehicles, ...).</li> <li>2. While entering the parking area the truck driver is informed about the free parking spaces together with the coordinates LAT/LON of the entry to the parking space and the type of the parking space. The driver has to select one parking space.</li> <li>3. When including a reference to the map, the way to the parking space is managed via road segments included in the MAP-message. This will enable the truck to find the way without using a navigation device. This would require new MAP messages.</li> <li>4. The truck must filter the parking spaces which are suited for parking of his truck with the help of the configured truck characteristics.</li> <li>5. The truck driver selects one parking space. This information is broadcasted to the C-ITS system and to other vehicles by the truck.</li> </ol>

	<p>6. His vehicle ITS subsystem will lead the truck driver along the shortest path to the free and suited parking space.</p> <p>7. The detection system identifies the parking space as occupied and stops distributing it.</p>  <p>Problem: In some cases, two consecutive trucks can head for the same parking space. For optimal results reservation is required, as the first truck heading to the parking space must block this for others, this is only possible at parking sites where reservation is possible.</p> <p>Problem: There is often a separation at the entrance of parking sites for passenger cars and trucks. The guidance should consider this fact and guide trucks on the appropriate path. This information might be missing in many navigation systems.</p> <p>Alternative solution: The selected position of the free parking space is transferred to the navigation device for routing.</p>
<p>Solution description</p>	
<p>Data source</p>	<p>e.g. local detector (confidence level), central ITS sub-system, OBU, vehicle ITS sub-system, roadside ITS sub-system, GNSS; internet (e.g. reservation, freight planning), user input</p>

Data sink, user	driver
C-ITS Messages	POIM-PA, MAPM
Prerequisites	<ul style="list-style-type: none"> <li>- extended POIM-PA</li> <li>- - extended MAPM</li> <li>- UI for the truck driver to select a parking space</li> </ul>
Penetration rate	1 vehicle
Expected Benefit	Safety: prevent truck drivers from unnecessary driving around and manoeuvring

Table 14: Description of use case 10

### 6.11 Use Case 11 ‘Guidance to free parking place’ (list)

This use case is like the use case described in 6.10 besides no map is used.

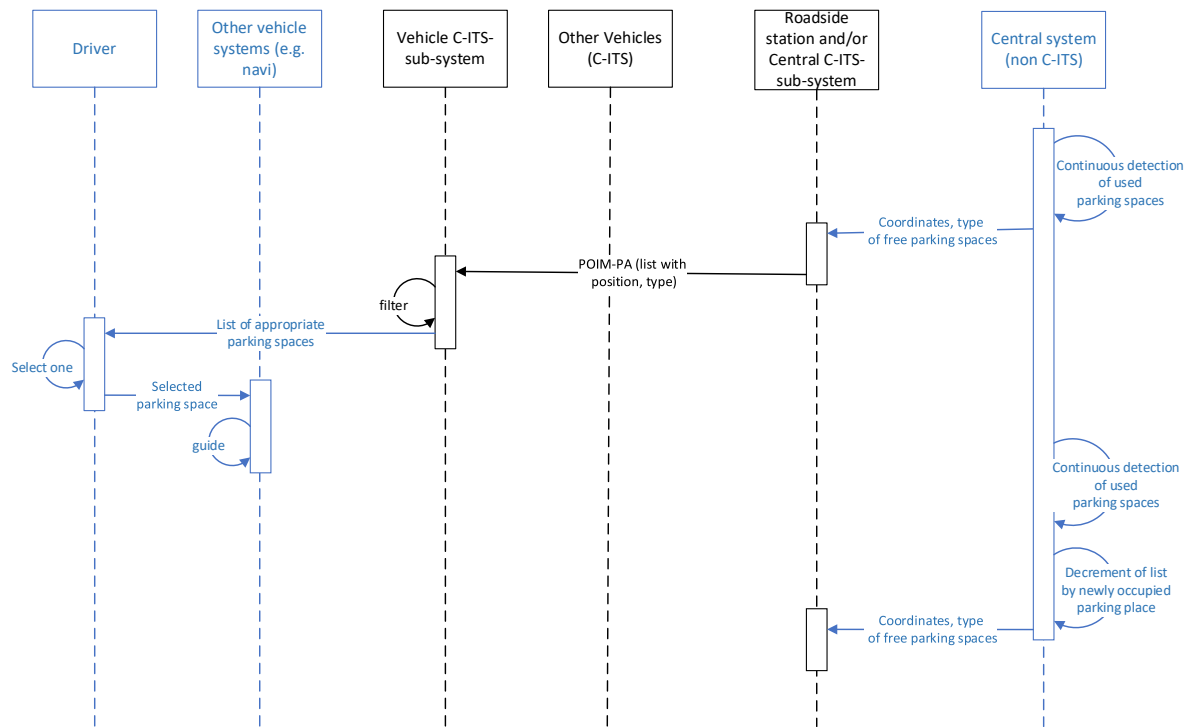

UC11	Use Case: Guidance to free parking place (list)
------	---

Figure 43: UML-sequence of use case 11

Guidance to free parking space (list)

ID	UC_guidance_11
Status	Valid
Priority	2
Deployment phase	day x
Roadmap, horizon	mid-term 3-5 years

Summary	< Brief description in one or two sentences >
Motivation	< Description of the rationale for the use case >
Roles	<ul style="list-style-type: none"> <li>- central management system for parking and detection</li> <li>- central ITS sub-system</li> <li>- roadside ITS sub-system</li> <li>- vehicle ITS sub-system</li> <li>- authority</li> </ul>
Description (incl. possible scenarios and desired outcome)	<ol style="list-style-type: none"> <li>1. The detection system of the parking site identifies the occupied and free parking spaces. The infrastructure generates a list of all free parking spaces with a classification of the type (status (free, reserved, ...), suited for short / long trucks, power supply, limited for non-dangerous goods vehicles, ....).</li> <li>2. While entering the parking area the truck driver is informed of the free parking spaces together with the coordinates LAT/LON of the entry to the parking space and the type of the parking space.</li> <li>3. The truck filters the parking spaces which are suited for parking of his truck with the help of the configured truck characteristics.</li> <li>4. The truck driver selects one parking space and his navigation device will lead the truck driver along the shortest path to the free and suited parking space.</li> <li>5. The detection system identifies the parking space as occupied and stops distributing it.</li> </ol>



Problem: In some cases, two consecutive trucks can head for the same parking space. For optimal results reservation is required, as the first truck heading to the parking space must block this for others, this is only possible at parking sites where reservation is possible

Solution description

Data source	e.g. local detector (confidence level), central ITS sub-system, OBU, vehicle ITS sub-system, roadside ITS sub-system, GNSS; internet (e.g. reservation, freight planning), user input
Data sink, user	driver
C-ITS Messages	POIM-PA
Prerequisites	- extended POIM-PA
Penetration rate	1 vehicle
Expected Benefit	Safety: prevent truck drivers from unnecessary driving around and manoeuvring

**Table 15: Description of use case 11**

### 6.12 Use case 12 ‘Warn approaching vehicles’

This use case is referring to the infrastructure (see 1.1.9) to detect incorrect parking and to warn the approaching driver, which has recently been installed in Germany by Die Autobahn GmbH for testing.

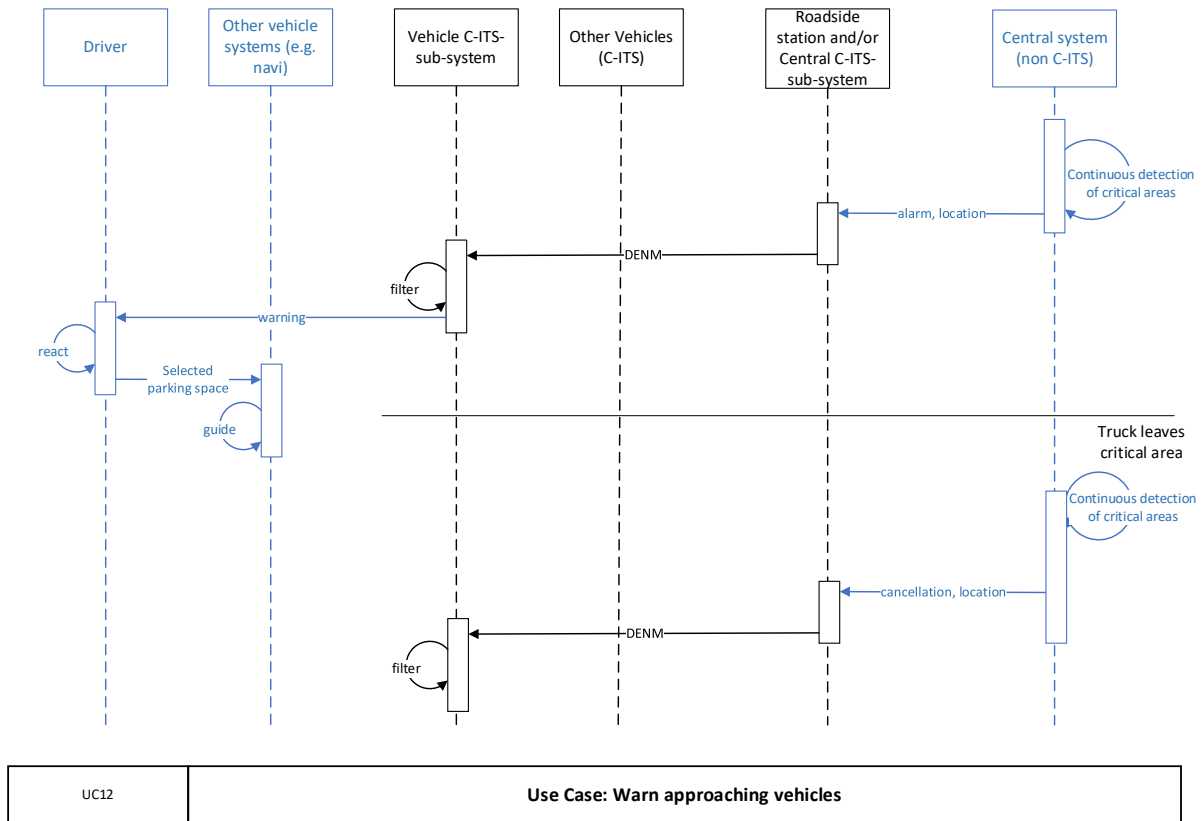

Figure 44: UML-sequence of use case 12

Warn approaching vehicles

ID	UC_parking_12
Status	Valid
Priority	1
Deployment phase	day x
Roadmap, horizon	mid-term 3-5 years

Summary	<p>A prerequisite for this use case is an existing detection system (see Figure 25) at or near the entrance lanes to a rest area or a parking site.</p> <p>Once the detection system has reported a wrongly parked vehicle or any other obstacle the central system is generating a warning message.</p>
Motivation	Reduce the number of accidents at the entrance to parking sites.
Roles	<ul style="list-style-type: none"> <li>- central management system for parking and detection</li> <li>- central ITS sub-system</li> <li>- roadside ITS sub-system</li> <li>- vehicle ITS sub-system</li> </ul>
Description (incl. possible scenarios and desired outcome)	<ol style="list-style-type: none"> <li>1. Central management system for parking as detectors like laser or lidar and detects the vehicle / obstacle in a restricted area.</li> <li>2. The central ITS-subsystem generates a DENM which includes a warning for the approaching vehicles.</li> <li>3. Once the vehicle has left the critical area a cancellation message is sent.</li> </ol>

Solution description

Data source	infrastructure
Data sink, user	drivers of any approaching traffic participants
C-ITS Messages	DENM
Prerequisites	<ul style="list-style-type: none"> <li>- Existing infrastructure (detection system)</li> </ul>
Penetration rate	1 vehicle
Expected Benefit	Safety: to prevent from crashes of parking and moving vehicles

**Table 16: Description of use case 12**

---

## 2 Message Types, Triggering Conditions and Message Content

---

The current setting of members of the work item does not allow to go into the depth of the messages and message containers. Therefore, the UML-diagrams and the description of the use cases do contain only the most likely message type. Whether the message type can currently manage to transfer the expected type of data or can include the described type of data needs to be clarified in a follow up work item. This mainly refers to the recently defined POIM/POIM-PA message.

[https://forge.etsi.org/rep/ITS/asn1/pa\\_ts103916/-/blob/release2/POIM-ParkingAvailability.asn](https://forge.etsi.org/rep/ITS/asn1/pa_ts103916/-/blob/release2/POIM-ParkingAvailability.asn)

The following Table 17 lists in a condensed form the C-ITS messages which are required in each use case. The following abbreviations are used.

C central ITS-sub-system

R roadside ITS-sub-system

V vehicle ITS sub-system

The numbers indicate the sequence of the messages.

Use Case	Name	CAM	DENM	POIM / POIM-PA	IVIM	MAP
1	Free Capacity (detectors)			C: generate R: transmit V: receive / display	alternative possibility: C: generate R: transmit V: receive / display)	
2	Free Capacity (geofence)	1. V: generate and transmit R: receive C: analyze		2. C: generate R: transmit V: receive / display	2. alternative possibility C: generate R: transmit V: receive / display)	
3	Dangerous Parking Position		2. V: generate R: transmit C: receive / analyze 2. V: generate Other V: receive 3. C: generate R: transmit V: receive (as vehicle is shut off the central system 1 has to continue to resend)			1. C: generate R: transmit V: receive / analyze  (it should be checked whether characteristics of parking area can also be included in the POIM-PA
4	Misuse of Parking Space	1. V: generate and transmit	2. C: generate R: transmit			

Use Case	Name	CAM	DENM	POIM / POIM-PA	IVIM	MAP
		R: receive C: analyse	V: receive / analyze			
5	Misuse of Parking Space	2. optional: V: generate R: transmit C: analyse		1. C: generate R: transmit V: receive / analyze		
6	Dangerous parking (outside official parking infrastructure)		1. V: generate R: transmit Other V: receive C: receive and analyze  2. V: generate and transmit cancellation R: receive Other V: receive C: receive			
7	Dangerous parking (outside official parking infrastructure)	1. V: generate and transmit R: receive C: receive  3. truck leaves V: generate and transmit	2. C: generate R: transmit V: receive / analyze Other V: receive  4. C: generate R: transmit			

Use Case	Name	CAM	DENM	POIM / POIM-PA	IVIM	MAP
		R: receive C: receive	V: receive			
8	Departure Time (infrastructure) Subcase truck has entered the right lane	1. V: generate and transmit R: receive C: receive		1. V: generate and transmit R: receive C: receive  4. C: generate R: transmit Other V: receive / display	2. C: generate R: transmit V: receive / display	
9	Departure Time (infrastructure) Subcase truck has entered the wrong lane	1 V: generate and transmit R: receive C: receive		1. V: generate and transmit R: receive C: receive  2. V: generate and transmit R: receive C: receive  3.		

Use Case	Name	CAM	DENM	POIM / POIM-PA	IVIM	MAP
				C: generate and transmit R: receive Other V: receive		
10	Guidance to free parking space (list+map)			1. C: generate R: transmit V: receive / display  2. V: generate R: transmit C: receive / analyze Other V: receive		1. C: generate R: transmit V: receive / analyze,
11	Guidance to free parking space (list)			1. C: generate R: transmit V: receive / display		
12	Warn approaching vehicles		1. C: generate R: transmit V: receive / display  2. cancellation C: generate R: transmit V:receive / display			

---

**Table 17: List of defined use cases and the required C-ITS messages per use case**

### 3 Appendix

#### 6.13 Related documents

Number	Reference
[1]	DIRECTIVE 2010/40/EU OF THE EUROPEAN PARLIAMENT AND OF THE COUNCIL on the framework for the deployment of Intelligent Transport Systems in the field of road transport and for interfaces with other modes of transport  Period 2024 - 2028
[2]	ETSI EN 302 890-1: Intelligent Transport Systems (ITS); Facilities layer function; Service Announcement (SA)
[3]	French C-ITS Deployment Coordination committee: Common technical specifications for use  cases - F1 - Information on parking lots, location, availability and services (I2V) Ver 4.20
[4]	COMMISSION DELEGATED REGULATION (EU) No, 885/2013 supplementing ITS Directive 2010/40/EU
[5]	ETSI ITS WG1 Document ITSWG1(22)060025: Parking Availability Service Specification; Release 2
[6]	Alliance for Parking Data Standards (APDS) <a href="https://www.allianceforparkingdatastandards.org">https://www.allianceforparkingdatastandards.org</a>
[7]	ISO/TC204 WG19 ISO/PWI 24321 Intelligent transport systems: Deployment of data standards for the parking industry
[8]	ETSI TS 101 556-4 (2022-09): Intelligent Transport Systems (ITS);  Point Of Interest (POI) Notification;  Part 4: Specification of Parking Availability Service
[9]	C-Roads: Common C-ITS Service Definitions: Parking Information V 2.1.0 Draft
[10]	ETSI EN 302 665 V1.1.1 (2010-09): Intelligent Transport Systems (ITS); Communications Architecture  <a href="https://www.etsi.org/deliver/etsi_en/302600_302699/302665/01.01.01_60/en_302665v010101p.pdf">https://www.etsi.org/deliver/etsi_en/302600_302699/302665/01.01.01_60/en_302665v010101p.pdf</a>
[11]	ETSI TS 102 894-2 V1.3.1 (2018-08): Intelligent Transport Systems (ITS);  Users and applications requirements;  Part 2: Applications and facilities layer

	common data dictionary
[12]	Car2Car Communication Consortium: Guidance for day 2 aand beyond roadmap Document 2072 V 1.1.0 2019

## 6.14 Use Cases which did not fit to the initial criteria but might be interesting in the future

### 3.1.1 Use Case 13 ‘Where is my trailer?’

This use case requires processes which are related to individual fleet management, e.g the internal transmission of positions and IDs. This use case further needs a basic communication infrastructure on the trailer.

There exist situations where the truck driver parks the trailer in the parking area and leaves the parking area with the truck for any reason. After a while he or any other truck returns to pick up the trailer. Especially in the second case the position of the trailer is not exactly known and requires some search process.

Trailer finding, Truck must find the right semi-trailer which is somewhere parked in the parking area.

Problem:

- That case would require two C-ITS stations for truck and trailer. During the period when the trailer is parked alone power supply will be needed on the trailer
- Trailer has telematic module for telecommunication and GNSS, and other electronic components of trailer

About the case truck leaves its trailer: <https://www.eurotransport.de/artikel/blockierte-lkw-parkplaetze-polizei-greift-durch-11214527.html>

Use case 13	Where is my trailer?
Description	<p>A truck leaves its trailer somewhere at a parking area or on the road. The trailer is equipped with a telematic module for telecommunication, with GNSS and other electronic components of trailer.</p> <p>The trailer sends ITS-G5 messages (CAM) to e.g. a RSU (or following to a trailer management system). The messages contain the position, coupling relevant parameters and a trailer ID other than license plate (public ID, lifetime ID, temporary ID). (Discuss privacy policy of trailer ID and a-la-carte container containing other relevant information)</p> <p>Idea: use ID of parking space, GNSS position</p> <p>The RSU distributes the message continuously as long as the trailer is located within a defined area of the parking area (info via ITS-G5 MAP).</p> <p>The same truck or any other truck returns to pick up the trailer.</p> <p>When the pick-up truck enters, he will get the information of the ID of the parking space or the GNSS position.</p> <p>The truck has received the trailer ID on a way out of scope of this Work Item. With this information the truck can select the relevant information out of all messages with parked trailer information.</p> <p>Outlook: It would be nice if a process could be found which activates the warning lights of the trailer when the truck is approaching e.g. when the trailer receives CAMs of the truck.</p> <p>Outlook: There are also self-propelled trailers or caravans, which are controlled e.g. via a remote control. Can/should these vehicles also send out a CAM message, for example?</p> <p>Outlook: It might be useful to add further status information of the trailer like temperature,.....</p>
Roles	<ul style="list-style-type: none"> <li>- truck</li> <li>- truck driver</li> <li>- vehicle ITS sub-system</li> <li>- roadside ITS subsystem</li> </ul>
Priority (1/2/3)	3
Deployment phase	day 2,
Roadmap, horizon	near 1-2 years

Data source	e.g. trailer with telematic equipment (connectivity, sensors,...), RSU,
Data sink, user	driver
C-ITS Messages	
Penetration rate	
Benefit	comfort, efficiency

Trailer parked aside the road



**Figure 45: Trailer parked aside the road**

This use case will be postponed because:

1. Trailer technical equipment is not available (battery, on board device)
2. Individual use case ([Telematik Datenservice \(cargobull.com\)](https://www.cargobull.com))
3. Trailers are towed by multiple truck companies and are not properly handled or maintained to ensure a good technical quality.

**3.1.2 Detection of free parking spaces by trucks**

New passenger cars are sometimes equipped with a parking assistance system. This system can detect free parking spaces when the vehicle is passing by. Once trucks are equipped with similar detectors, they might be also able to report free truck parking spaces.